



**VR-21, VR-41, & VR-51
VIBRATING ROD**



**OPERATING INSTRUCTIONS
PLEASE READ CAREFULLY**



Division of Garner Industries
7201 North 98th Street
Lincoln, NE 68507-9741
(402) 434-9102

TABLE OF CONTENTS

GENERAL SPECIFICATIONS	3
SAFETY SUMMARY	4
1.0 INTRODUCTION.....	5
2.0 APPLICATIONS	5
3.0 VERSIONS.....	5
4.0 INSTALLATION	6
4.1 Location and Mounting.....	6
Figure 1 Location Diagram	7
4.2 Input Power and Field Wiring	8
5.0 FAIL-SAFE SELECTION.....	9
5.1 Description	9
5.2 Fail-Safe High	9
5.3 Fail-Safe Low	9
6.0 SENSIVITY SELECTION.....	10
7.0 LED	10
8.0 REMOTE ELECTRONICS INSTALLATION	10
9.0 WARRANTY AND CUSTOMER SERVICE	11
10.0 DISPOSAL.....	11
FIGURE 3 VR-21.....	12
FIGURE 4 VR-41.....	13
FIGURE 5 VR-51.....	14
FIGURE 6 VR REMOTE ELECTRONICS MOUNTING AND WIRING	15
DECLARATION OF CONFORMITY	16



VR-21, VR-41, & VR-51 GENERAL SPECIFICATIONS

Power Supply:	20 to 250 V AC/DC
Power Consumption:	3VA
Ambient Temperature: (Electronics)	-4° F to +140° F (-20° C to +60° C)
Process Temperature: (Probe)	-4° F to +176° F (-20° C to +80° C)
Enclosure:	Powder Coated: Type 4X, 5, & 12 Bare Aluminum: Type 4, 5, & 12
Relay Output:	DPDT contacts; 5 Amps 250 VAC
Fail-Safe:	Selectable "High" or "Low" level modes.
Mounting:	VR-21, VR-41, & VR-51 = 1 1/2" NPT
 Conduit Entries:	3/4" NPT
Minimum Material Density:	1.9 lb. / cu. ft (30 g/ liter)

SAFETY SUMMARY

Review the following safety precautions to avoid injury and prevent damage to the equipment.

The product should be installed, commissioned, and maintained by qualified and authorized personnel only.

Install according to installation instructions and comply with all National and Local codes.

Use electrical wire that is sized and rated for the maximum voltage and current of the application.

Properly ground the enclosure to an adequate earth ground.

Observe all terminal and relay contact ratings as called out on the nameplate and in the installation manual.

Ensure that the enclosure cover is in place and secured tightly during normal operation.

If this product is used in a manner not specified by the manufacturer the safety protection could be compromised.

Safety Terms and Symbols



WARNING: Warning statements identify conditions or practices that could result in injury or loss of life.
Risk of electrical shock.



CAUTION: Caution statements identify conditions or practices that could result in damage to this product or other property.

1.0 INTRODUCTION

The BinMaster VR vibrating rods are point level controls used to detect the presence or absence of granular or powdered material. The vibrating rod operates by exciting the blade of unit to causing it to vibrate at its mechanical resonance frequency of about 290 Hz. When material covers the blade of the probe, the vibration stops. This is sensed by the electronic circuitry causing the relay contacts to change status. When the blade becomes uncovered, the vibration will restart and the relay contacts will change back. Since only the end of the vibrating blade is sensitive and not the base, buildup on the vessel wall has no influence on the sensor. The shape of the blade and its vibration have a self cleaning effect.

2.0 APPLICATIONS

The BinMaster VR vibrating rod can be used in bins, silos, and hoppers to detect many different granular or powdered materials. The following list shows some of these materials:

Animal feed	Powdered cellulose
Beans	Powdered clay
Chalk	Powdered milk
Coffee beans	Salt
Coffee (freeze-dried)	Soda ash
Coffee (ground)	Soot (dry pellets)
Flour	Spices
Foundry sand	Styrene chips
Frozen potato chips	Sugar
Glass (finely ground)	Sweets
Granular plastics	Styrofoam
Gravel	Tea (leaf)
Peanuts	Tobacco
Polystyrene powder	Wood shavings

3.0 VERSIONS

The BinMaster VR is available in 3 different versions:

- VR-21 - 1 1/2 in. NPT mount, standard insertion length 7.5 in. (190mm)
- VR-41 - 1 1/2 in. NPT mount, with threaded pipe extension for insertion length from 14 in. up to 13 ft.
- VR-51 - 1 1/2 in. NPT mount, with cable extension for insertion length from 18 in. up to 19.5 ft.

3.1 SPECIAL SEDIMENT MODEL

Application: The BinMaster VR-SED is a special configuration of the VR-21 / VR-41 level control instrument. It is designed to detect the level of solid material that has settled in water. A typical application is the detection of sand in front of pumping systems.

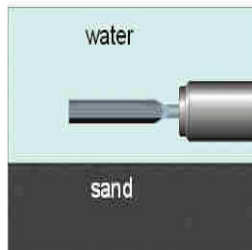

Function: A piezo system brings rod to vibrate at its resonant frequency. The vibrating system is tuned to work in water. If solid material covers the rod, it damps the vibration. An electronics circuit switches a binary output signal. When the rod gets uncovered, it starts vibrating again and the output switches back.

SPECIAL INSTRUCTIONS FOR SEDIMENT MODEL VIBRATING ROD

General: This special sediment model vibrating rod is tuned to work (vibrate) in water. This means that it may not vibrate in air which would result in a covered indication. To test the sediment model vibrating rod, you have to put the vibrating blade into water. The sediment model is not usable for detecting liquids or solids in air. The blade of the BinMaster VR-SED must have a distance of at least 4 inches (100mm) to the container wall. If the blade gets closer than this to the container wall, then the vibration could be damped by reflections of the container wall.

Sensitivity: For the sediment model vibrating rod, only the sensitivity settings B or C can be used. This setting depends on the weight of the settled material and the water/material mixture.

B Higher sensitivity: The vibration gets damped earlier than on position C. Depending on the density of the material, the relay will switch when the water/material mixture on top of the settlement just reaches the vibrating blade.

C Lower sensitivity: The vibration gets damped later than on position B when the vibrating blade gets fully covered by the settled material.

4.0 INSTALLATION

4.1 Location and Mounting

Figure 1 shows the typical installation possibilities of the BinMaster VR units.

The BinMaster VR is installed by screwing the male mounting threads into a 1 1/2" NPT coupling or mounting flange. Use a 2 inch (50mm) wrench to tighten the unit into the mounting socket. If side mounting the VR, it must be turned until the blade is vertically oriented, so that material can flow freely over the blade and does not rest on it causing false alarms. Use the round indentation on the 2 in. hex collar to identify the blade orientation. When the indentation is up the blade is oriented correctly. Refer to Figure 1 for a view of blade orientation

WARNING: Do not screw in by turning the enclosure housing!

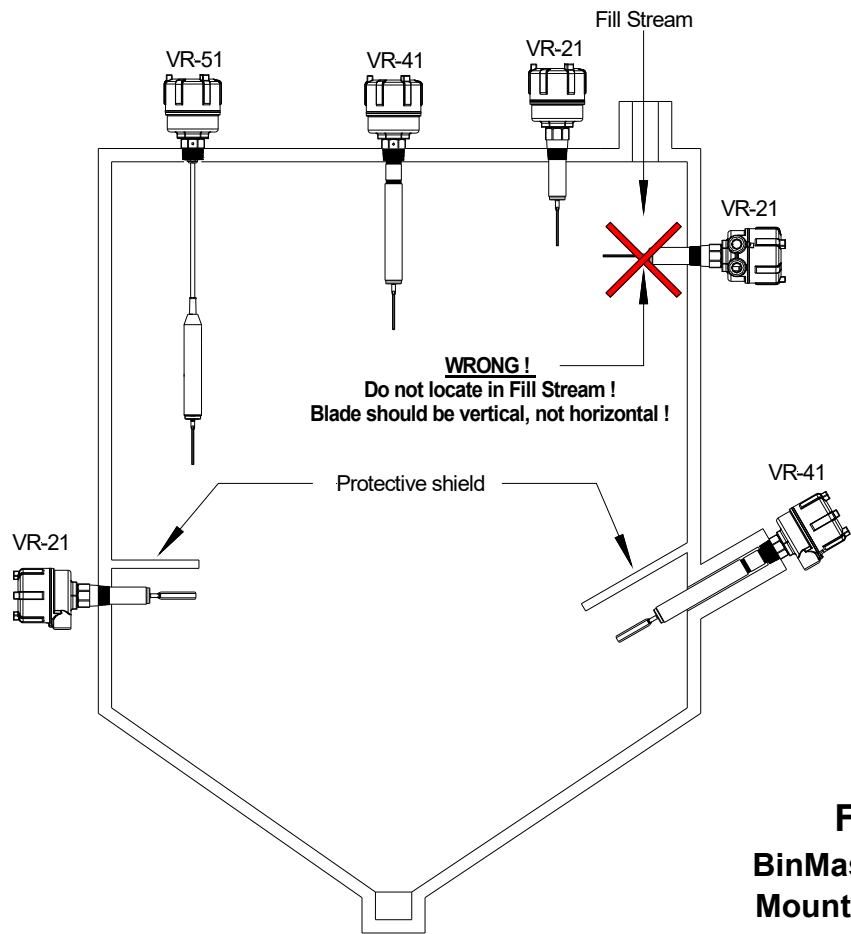
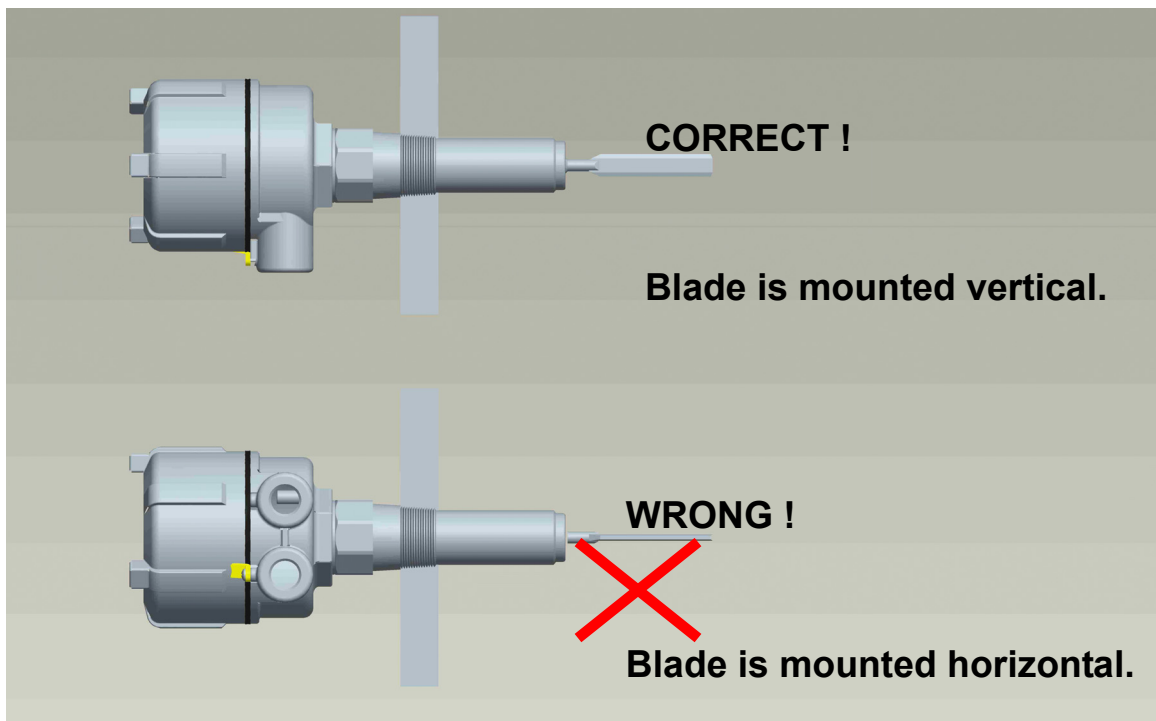

Figure 1
BinMaster VR series
Mounting Locations



The conduit entries must always point downwards to prevent moisture from seeping inside the housing. If the housing is not in the correct position after the probe has been firmly screwed into the bin wall, proceed as follows:

- Remove the cover of the housing.
- Unscrew and remove the 3 mounting screws for the upper circuit board.
- Remove the upper circuit board. Be careful not to bend the interconnect pins on the bottom of the circuit board.
- Unscrew and remove the 3 hex standoffs that secure the lower circuit board.
- Remove the lower circuit board. The wires from the probe do not need to be removed from the circuit board, but care should be taken not to damage the circuit board or wires.
- Use a 10mm wrench or socket to loosen and remove the nut that secures the housing to the vibrating rod assembly.
- Lift off the housing from the vibrating rod assembly. Take care not to damage the wires or the circuit board.
- The housing can be rotated in 90° increments to achieve an orientation that has the conduit entries pointing downward.
- Place the housing back on the vibrating rod assembly so that the tube for the wires is in one of the 4 notches in the housing.
- Replace the flat retaining washer and flat washer and screw the nut back on the stud from the vibrating rod assembly. Firmly tighten the nut.
- Replace the lower circuit board and secure it with the 3 standoffs.
- Replace the upper circuit board. Be sure to align all of the interconnecting pins on the bottom of the upper circuit board and plug the 2 boards together.
- Secure the upper circuit board with the 3 mounting screws.

4.2 Input Power and Field Wiring



The BinMaster VR units have a wide voltage range power capable of being powered from any voltage from 20 volts to 250 volts AC or DC. The terminals on the circuit board for the power supply and the relay contacts allows for a maximum conductor size of 12 AWG. An equipment grounding connection (earth ground) should be supplied to the unit for safety. See the diagram below for terminal and component identification. Field wiring should conform to all national and local electrical codes and any other agency or authority having jurisdiction over the installation.

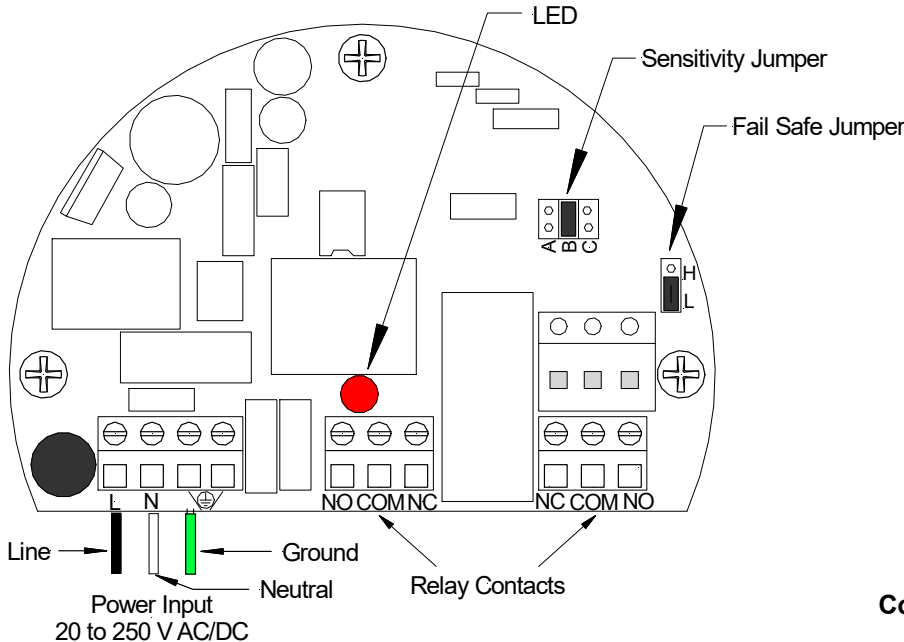

Figure 2
Wiring Terminal &
Component Identification

5.0 FAIL-SAFE SELECTION

5.1 Description

A Fail-Safe condition means that the relay contact positions are set up so that in the event of a power failure the relay will be de-energized and the contacts will indicate a condition that is deemed safe for the application. (Refer to Figure 2 for the location of the Fail-Safe selection switch.)

5.2 Fail-Safe High

Fail-Safe High means that the relay will be energized when the probe is uncovered and will de-energize when the probe is covered. In this mode, a power failure will cause the relay contacts to indicate that the probe is covered whether it is or not.

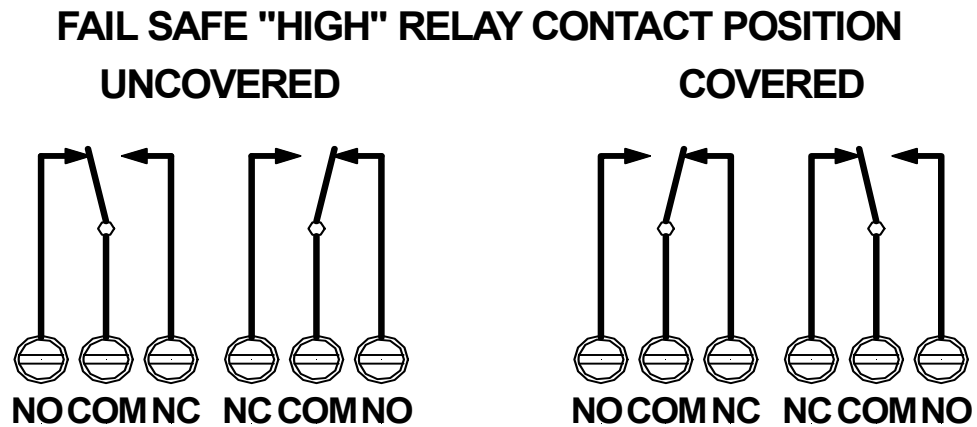

5.3 Fail-Safe Low

Fail-Safe Low means that the relay will be de-energized when the probe is uncovered and will energize when the probe is covered. In this mode, a power failure will cause the relay contacts to indicate that the probe is uncovered whether it is or not.

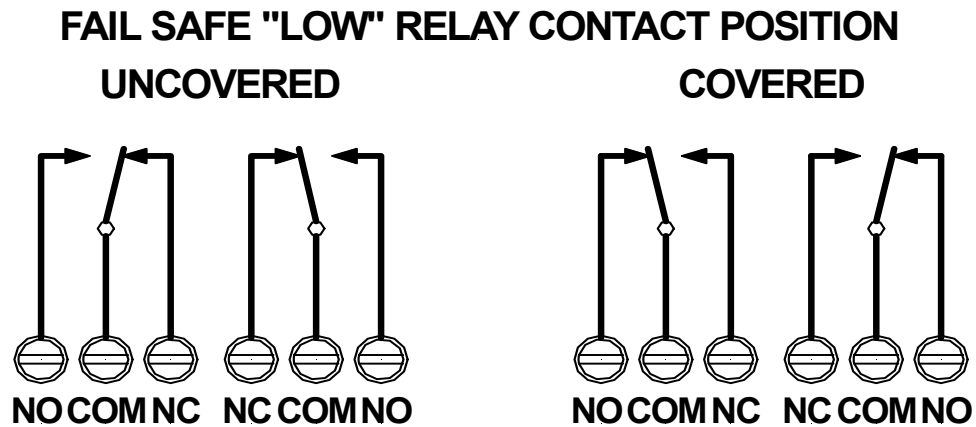

6.0 Sensitivity Selection

Sensitivity Setting (typical)

Material Characteristics

Pos. A:	Use this setting only for very light material with densities down to 1.25 lb./cu.ft., (20g/l). The sensitivity is very high at this setting.
Pos. B:	Standard setting, sufficient for most materials.
Pos. C:	For heavy materials with high densities which may form a deposit on the vibrating blade. As the sensitivity of the instrument is low at position C, very light material such as expanded styrofoam cannot be detected at this setting!

For special model SEDIMENT VR only B or C must be used, see special instructions for SEDIMENT!

7.0 LED

The LED on the circuit board is a visual indication of the status of the vibrating rod relay. The LED will be flashing when the relay is de-energized and will be ON solid when the relay is energized. The Fail Safe jumper position will determine when the relay is energized.

Fail Safe Setting	V Rod Status	LED Status	Relay Status
L	UNCOVERED	FLASHING	DE-ENERGIZED (COM CONNECTED TO NC)
L	COVERED	ON SOLID	ENERGIZED (COM CONNECTED TO NO)
H	UNCOVERED	ON SOLID	ENERGIZED (COM CONNECTED TO NO)
H	COVERED	FLASHING	DE-ENERGIZED (COM CONNECTED TO NC)

8.0 REMOTE ELECTRONICS INSTALLATION

In some applications such as excessive vibration or ambient temperatures above +140° F, it may be necessary to locate the electronic circuit board away from the vibrating rod. In these applications, a separate remote enclosure is used to mount the circuit board, and a special cable with individually shielded conductors is used to interconnect the circuit board to the vibrating rod unit. The remote electronics option is available for the VR-21, VR-41, and VR-51 vibrating rods.

Figure 6 shows the mounting hole locations for the remote electronics enclosure. The interconnecting cable connections are also shown in Figure 6. The input power is supplied to the remote electronics and the special individually shielded conductor cable is routed between the remote electronics and the vibrating rod. The interconnect cable will have a wire connecting terminal "T" on the remote board to terminal "T" in the vibrating rod; terminal "R" on the remote board to terminal "R" in the vibrating rod; and signal ground on the remote board to signal ground in the vibrating rod.

9.0 WARRANTY AND CUSTOMER SERVICE

9.1 Limited Warranty

The manufacturer warrants this equipment for two (2) years according to the following terms:

- 1.) This warranty extends to the original purchaser only and commences on the date of original purchase. The original purchaser must mail to the manufacturer the "Warranty Registration" card to confirm the equipment purchase. Failure to do so may void the warranty.
- 2.) The manufacturer will repair or replace any part of this equipment found to be defective, provided such part is delivered prepaid, to the factory. Manufacturer's obligation is limited to the cost of material and labor to repair or replace and does not include transportation expenses.
- 3.) This warranty shall not apply to any product that has, in our judgment, been tampered with, altered, subject to misuse, neglect or accident. In addition, the warranty does not extend to repairs made necessary by normal wear.
- 4.) This warranty is in lieu of all other warranties, expressed or implied.

9.2 Customer Service

BinMaster offers a toll-free Customer Service phone number **1-800-278-4241**. You may call the Customer Service Department for technical and application assistance Monday through Friday from 8:00AM to 5:00 PM Central Time. International customers call us at **(402) 434-9102** or reach us via fax at **(402) 434-9133**.

10.0 DISPOSAL

This product consists of materials that can be recycled by specialized recycling companies. It uses recyclable materials and the electronics are designed to be easily separated. Consult local authorities for proper disposal locations.

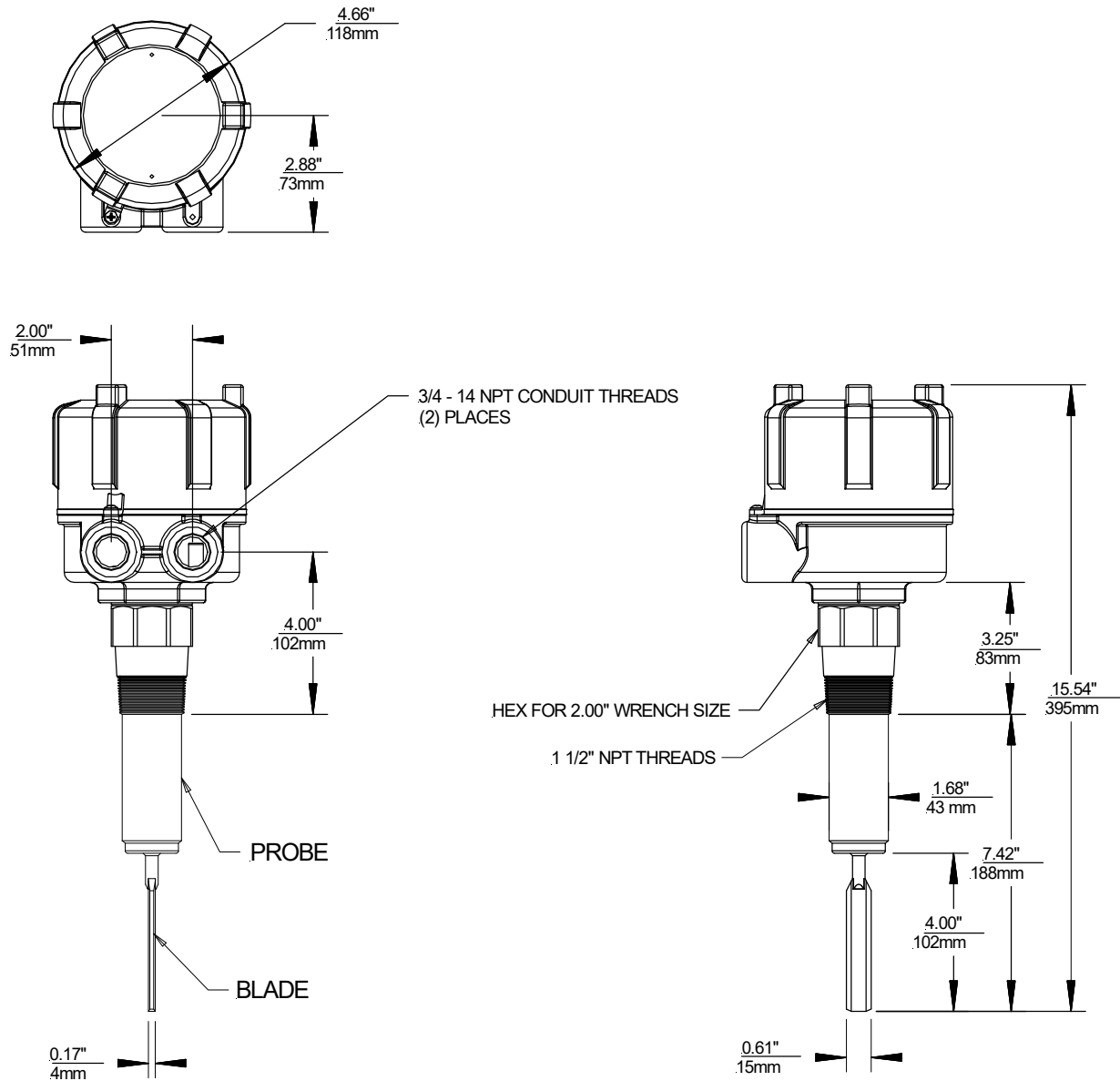

Figure 3
VR-21

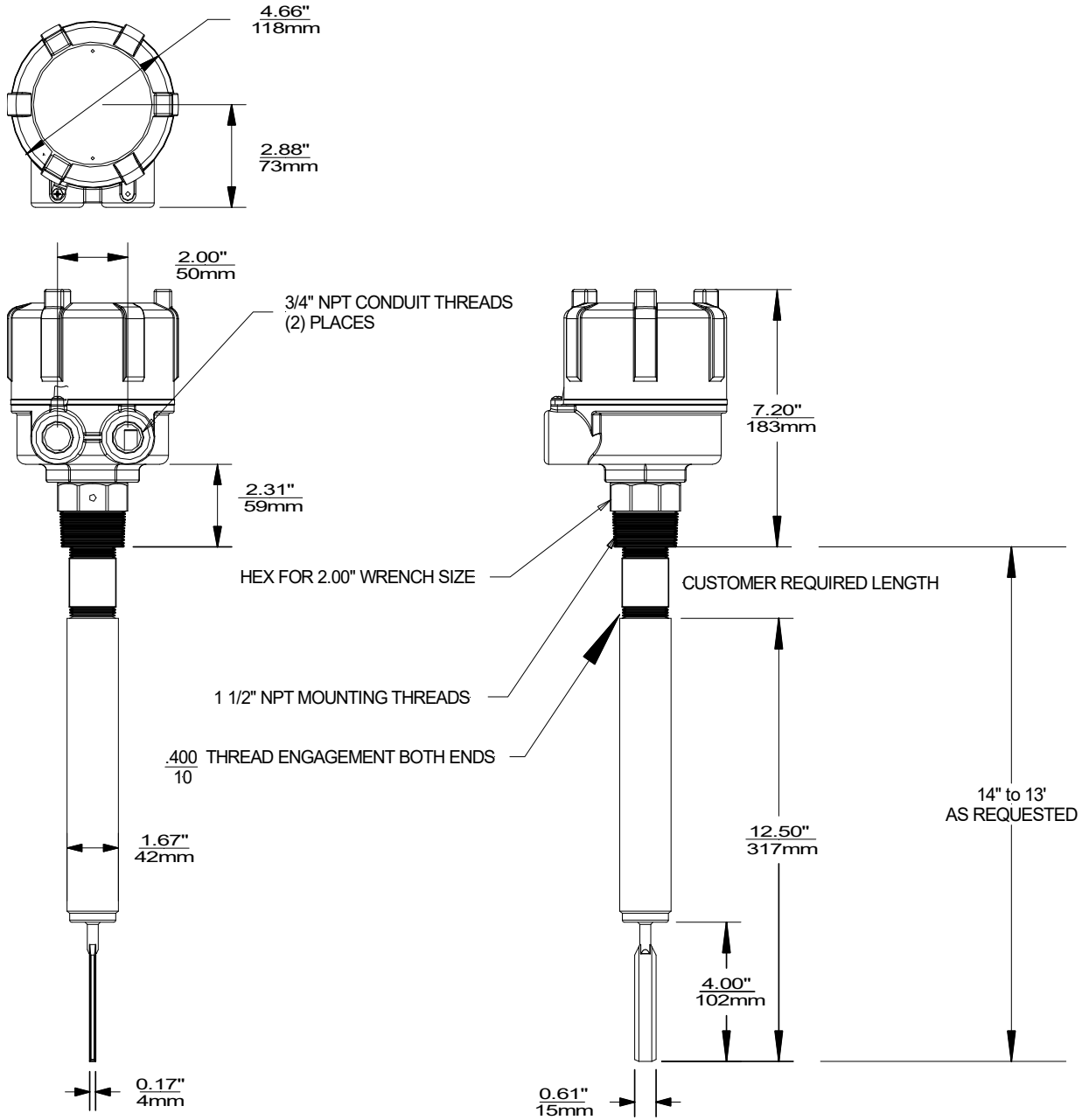

Figure 4 VR-41

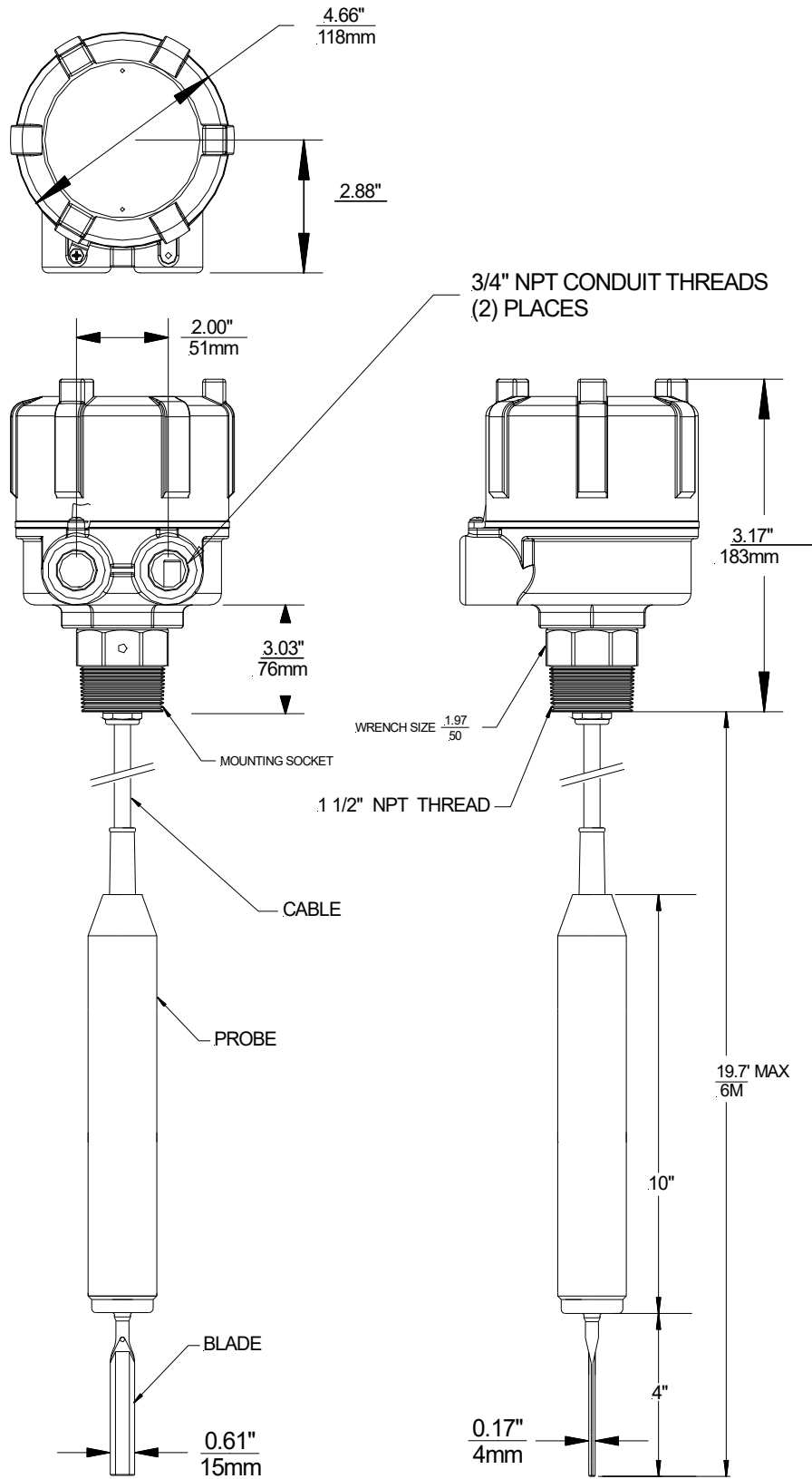

Figure 5 VR-51

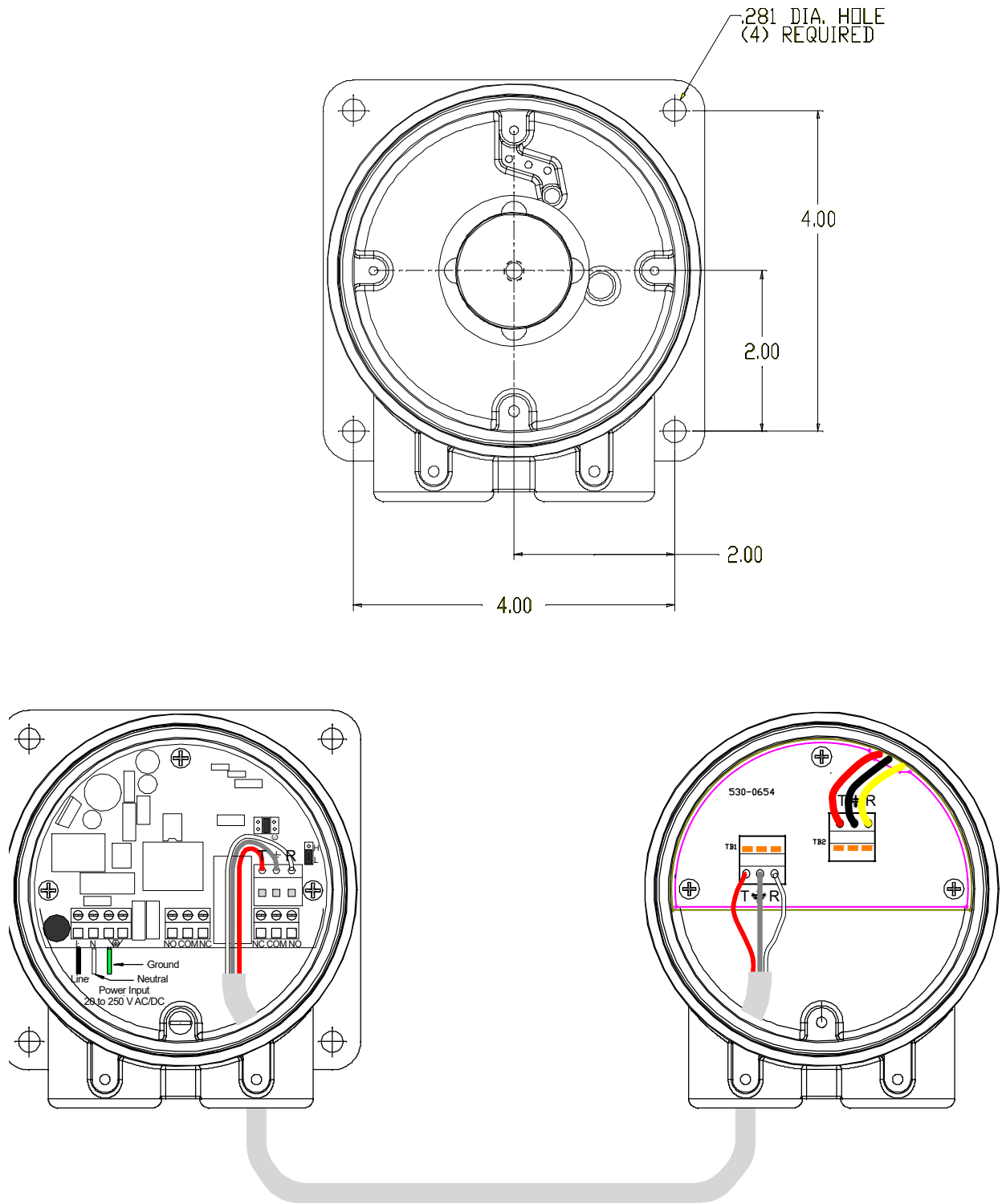

Figure 6
VR Remote Mounting Dimensions and Wiring

Declaration of Conformity

BinMaster Level Controls
7201 North 98th Street
Lincoln, NE 68507-9741
Phone: 402-434-9100, Fax: 402-434-9133

BinMaster declares that the VR series vibrating rod level control devices as listed below comply with the following directives and harmonized standards. This product if installed, operated and maintained as described in this manual will provide a safe and reliable point level control device for bulk solid materials.

Low Voltage Directive 73/23/EEC
Standard IEC 61010-1:2001

Product: Vibrating rod point level control device.

Models: VR-21, VR-41, and VR-51

All test reports and documentation are held and can be obtained from BinMaster.

Manufacturing Location: Lincoln, Nebraska, USA

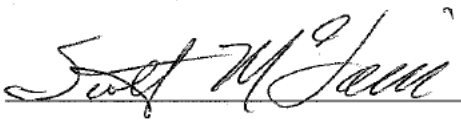

Scott McLain
President
5/12/2011

Mounting Instructions

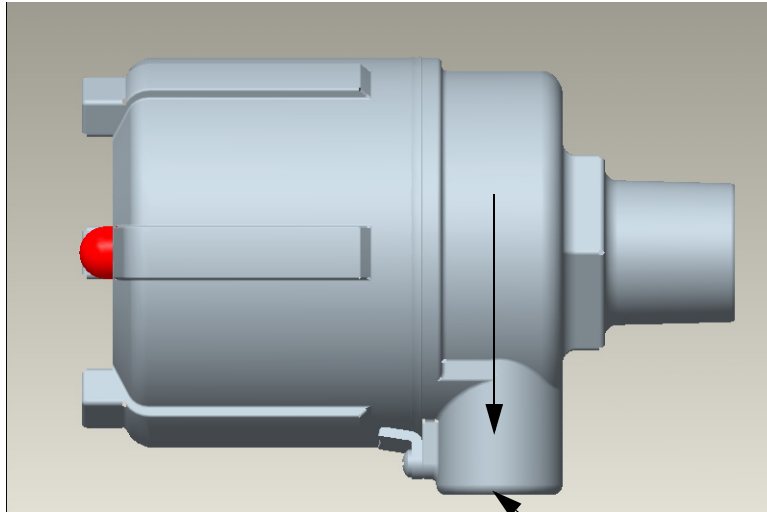

Always Mount Unit With
Conduit opening down

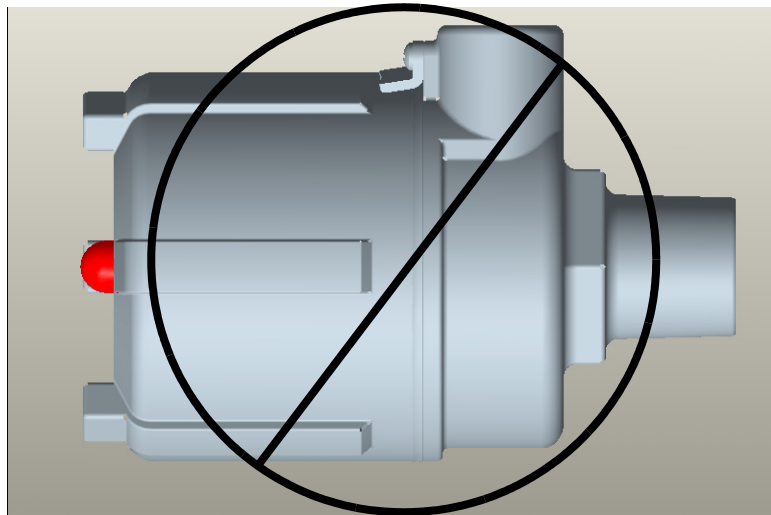

Conduit Seal

When installing this level indicator in environments where it is possible for moisture or moist air to enter the enclosure through the electrical conduit, the conduit opening should be sealed with a duct seal compound or putty appropriate for the purpose.

BINMASTER[®]

Division of Garner Industries
7201 No. 98th Street
Lincoln, NE 68507