



# **BMRX-200**

## **Rotary Level Indicator**

Operating Instructions  
Please Read Carefully

BinMaster: Division of Garner Industries LLC  
Lincoln, NE  
402-434-9102

# TABLE OF CONTENTS

GENERAL SPECIFICATIONS.....	3
SAFETY SUMMARY .....	4
1.0 INTRODUCTION .....	5
2.0 INSTALLATION.....	5
2.1 Mounting Summary.....	5
2.2 Location and Mounting .....	7
2.3 Input Power and Field Wiring .....	9
2.4 Grounding .....	10
3.0 DPDT RELAY.....	10
3.1 Fail Safe High .....	10
3.2 Fail Safe Low .....	10
4.0 WARRANTY AND CUSTOMER SERVICE.....	11
4.1 Limited Warranty .....	11
4.2 Customer Service .....	11
5.0 DISPOSAL .....	11

# SPECIFICATIONS

## BMRX-200 GENERAL SPECIFICATIONS

Power Supply:	115 VAC 50/60 Hz 230 VAC 50/60 Hz 24 VAC 50/60 Hz
Supply Tolerance:	-15% to +10%
Load:	5 VA
Ambient Temperature: (Electronics)	-40°F to +131°F (-40°C to +55°C)
Process Temperature:	400°F (204°C)
Enclosure Type:	4X / IP66
Enclosure Material:	Die cast aluminum, powder coat finish
DPDT Relay Output:	10 Amps 250 VAC
Fail Safe:	Switch selectable "High" or "Low" level modes
Mounting:	1-1/4" NPT, 1-1/2" NPT, 1-1/2" Tri-clover
Approvals:	Hazardous Location Rating C/US Class II Div I Groups E, F & G
Standards:	UL 1203:2013Ed.5+R:16Feb2018 CSA C22.2#25:2017 Ed.4 UL 61010-1:2012 CSA C22.2#61010-1-12:2012  Conforms to UL STD 1203 Certified to CSA STD C22.2 #25
Conduit Entries:	3/4" NPT
Shaft Seal:	1/2 micron, 30 PSI



**Intertek**

5003113

# SAFETY

## SAFETY SUMMARY

Review the safety precautions to avoid injury and prevent damage to equipment.

The product should be installed, commissioned, and maintained by qualified, authorized personnel only.

Install according to instructions. Field wiring should conform to all national and local electrical codes and any other agency or authority having jurisdiction over the installation.

Use electrical wire that is sized and rated for the maximum voltage and current of the application. The internal grounding terminal shall be used as the equipment grounding means, and that the external terminal is only a supplemental bonding connection where local authorities permit or require such a connection.

Observe terminal and relay contact ratings on the nameplate and in the installation manual.

Ensure the enclosure cover is in place and secured tightly during normal operation. In potentially wet environments, thoroughly seal all conduit entries.

If this product is used in a manner not specified by the manufacturer safety protection could be compromised.

If dissimilar metals are used to mount the level control, the enclosure should be inspected for galvanic action every three years.

## Safety Terms and Symbols



**WARNING:** Warning statements identify conditions or practices that could result in injury or loss of life. Risk of electrical shock.

---



**CAUTION:** Caution statements identify conditions or practices that could result in damage to this product or other property.

---

# INTRODUCTION

## 1.0 INTRODUCTION

The BinMaster BMRX-200 is a rotary level sensor that provides reliable point level detection in bulk solids, including powder, pellet, and granular materials.

The BMRX-200 motor rotates the drive shaft and paddle at 1 RPM (0.833 RPM at 50Hz). When the material fills to the level of the indicator paddle, it causes the paddle to stop rotating indicating a covered condition. When the material falls away, the paddle resumes rotating to indicate an uncovered condition.

## 2.0 INSTALLATION

### 2.1 Mounting Summary

The BMRX-200 has three optional process fittings available to mount the indicator; 1.25" NPT, 1.5" NPT, or 1.5" tri-clover fitting. The BMRX-200 can be mounted using a mounting plate, welded in couplings, or mating the tri-clover fitting with a flanged end with an internal diameter big enough for the paddle to fit through.

#### Mounting Plates

Mounting plates allow installing a completely assembled rotary through the vessel side or top. The mounting plates have 6 bolt holes equally spaced on a 7-inch bolt circle. Mounting plates are available with 1.25" or 1.5" NPT half or full couplings dependent on the process fitting size of the rotary.

Half couplings are used for all side mount installations or if top mounting a rotary without using a guard pipe.

Full couplings are for top-of-vessel installations when using shaft extensions and shaft guard pipes. Do NOT use full couplings for side mounting. The void on the process side of a full coupling could allow material to pack in the void and interfere with rotation of the rotary shaft.

Cut a hole in the vessel wall large enough for the paddle to fit through. Place the gasket between the mounting plate and the vessel and install 6 mounting bolts through the mounting holes to secure the plate to the vessel.

#### Mounting without Mounting Plates

Select a coupling or tri-clover fitting that matches the size of the process fitting on the rotary. Cut a hole in the vessel big enough to fit the coupling through the vessel wall. Weld the coupling to the vessel well to seal out moisture and dust.

**Mounting Plates**

Mounting plates are needed when a completely assembled rotary is mounted on the bin wall from the outside. Cut a 5-1/2" hole in the bin. Drill six bolt holes around the hole to match the mounting plate. Bolt the plate, with the unit attached, into place. Mounting plates are available in carbon or stainless steel

**Figure 4**

**Full Coupling**

For use with all rotary level controls. Full coupling is used for top-of-bin installations where shaft extensions and shaft guards are used.

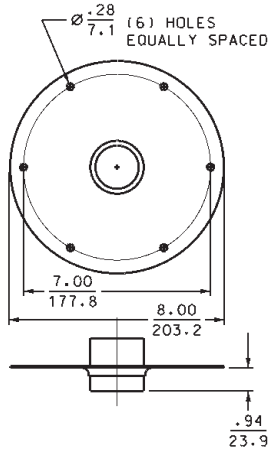

**Figure 5**

**Half Coupling**

For use with all rotary level controls. Half coupling is used primarily for side of bin installations.

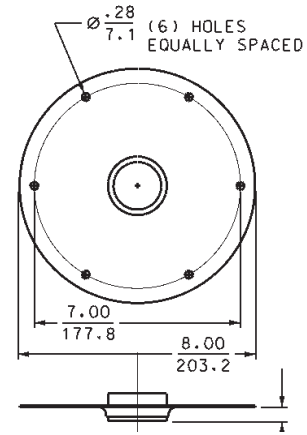

## 2.2 Locating and Mounting

### SIDE MOUNT

1. Determine location and cut hole inside of bin to fit outside diameter of 1-1/4" pipe coupling (1.950").
2. Weld on half of standard 1-1/4" pipe coupling to bin wall flush with inside of bin.
3. Insert hub into coupling and turn rotary so conduit entries are pointed down toward the ground.
4. Screw paddle into place and replace lock pin.
5. Shaft and paddle should be shielded in low level mounting to protect from material flow.
6. For side mounting, a solid coupler is recommended.

Figure 1

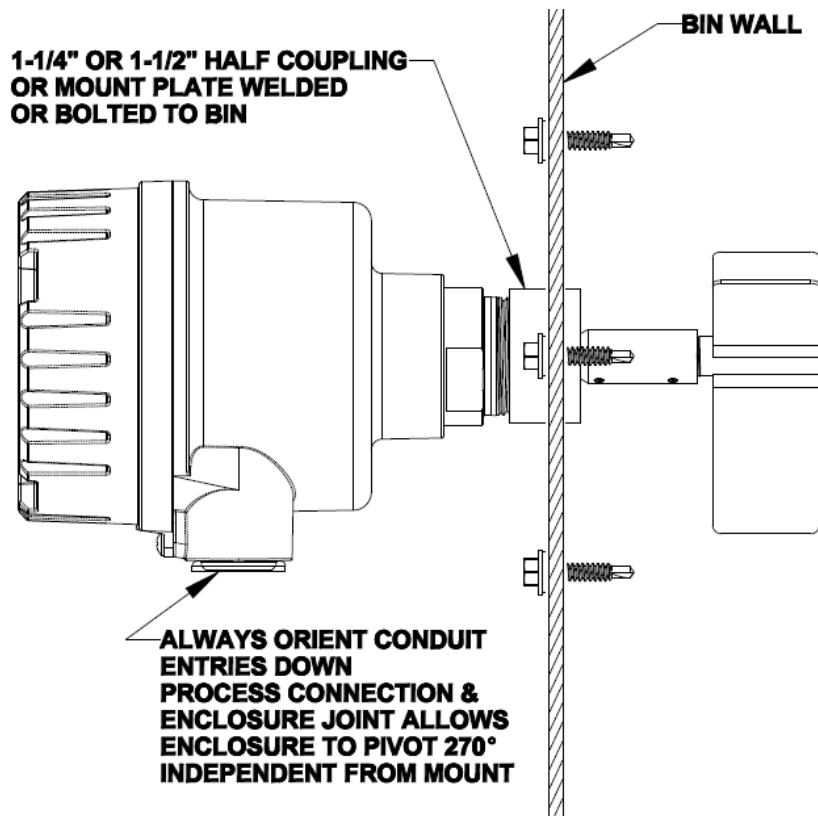

**TOP MOUNT**

1. Determine mounting location and cut a hole in top of bin to fit outside diameter of 1-1/4" pipe coupling (1.950").
2. Position coupling halfway into bin and weld to bin.
3. Turn rotary so conduit openings are in desired location.
4. Add 1/4" extension pipe of desired length with standard 1/4" coupling on bottom end.
5. Cut 1-1/4" support pipe approximately 4" shorter than overall length of 1/4" pipe shaft if used with flexible coupling.
6. Insert 1-1/4" pipe into coupling and tighten.
7. Insert paddle into 1/4" coupling and drill holes for lock pins.

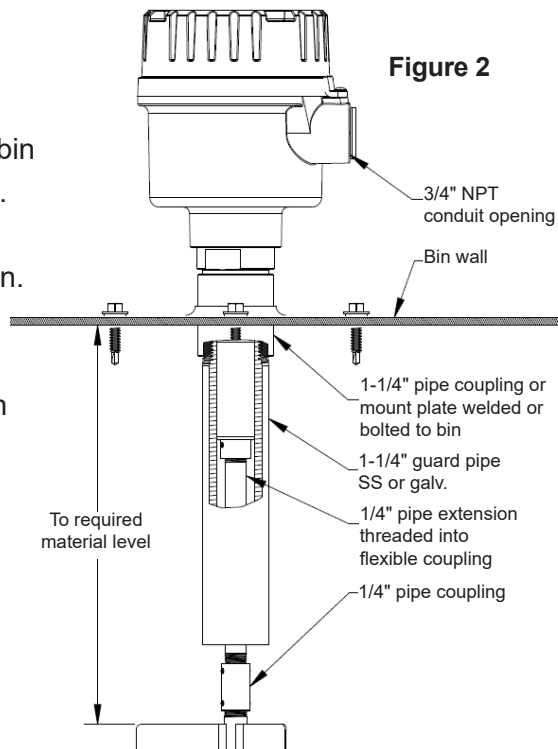

**MOUNTING**

Use the 1.70" flats provided on the process connection for tightening the instrument into the mounting coupler or mounting plate.

The enclosure can be rotated 360 degrees after the process connection is tight. NOTE: For side mount application, rotate enclosure conduit entries DOWN after the process connection is tight.

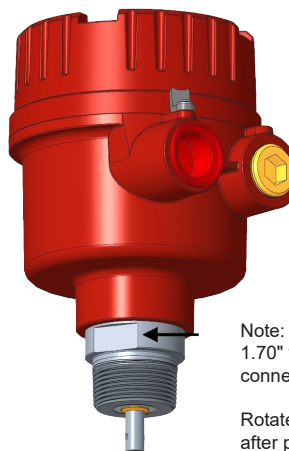

Note: Tighten/loosen only using the 1.70" flats provided on the process connection.

Rotate enclosure conduit entries down after process connection is tight.

**Mounting Orientation**

To prevent moisture or humidity from entering the unit when mounted on the side of the bin, the rotary MUST be mounted with the conduit entries facing down.

**Conduit Seal**

When installing the rotary in environments where moisture or moist air may enter the unit through the electrical conduit, the conduit openings should be sealed with an appropriate duct seal compound or putty.

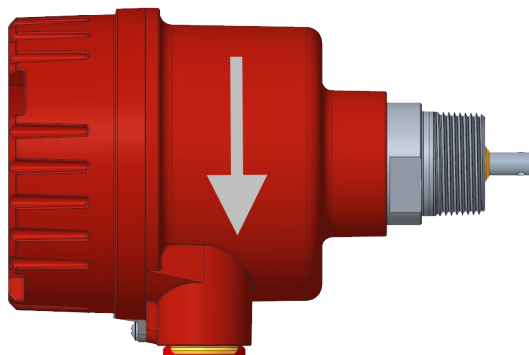

NOTE: Conduit entries must be fitted with a suitable sealing device for the Hazardous Location. All unused conduit entries must be sealed and if any conduit entry blanking plugs are removed or replaced, they must be fitted with a suitable certified sealing device.



**⚠ 2.3 Input Power and Field Wiring**

The BMRX-200 is available in 115 VAC, 230 VAC, and 24 VAC supply voltages. See the voltage rating on the nameplate for the supply voltage. Field wiring should conform to all national and local electrical codes and codes of any other agency or authority with jurisdiction over the installation. For power input, use wire sized and rated for the maximum voltage and current according to equipment ratings with a temperature rating of at least 70°C. For SPDT switch output, use wire sized and rated for the maximum voltage and current for the application, up to 250 VAC 10A, and has a temperature rating of at least 70°C. Installation must be done by qualified personnel. **NOTE: Open the screw terminals fully before inserting wiring.**

**BMRX-200 Wiring Input Power**

Power input to the BMRX-200 is connected to the POWER terminals labeled L and N.

**⚠ AC Models**

On AC models, if one of the conductors is grounded, connect to the N terminal. Connect the ungrounded conductor to the L terminal. If neither conductor is grounded, connect one to the N terminal and the other to the L terminal.

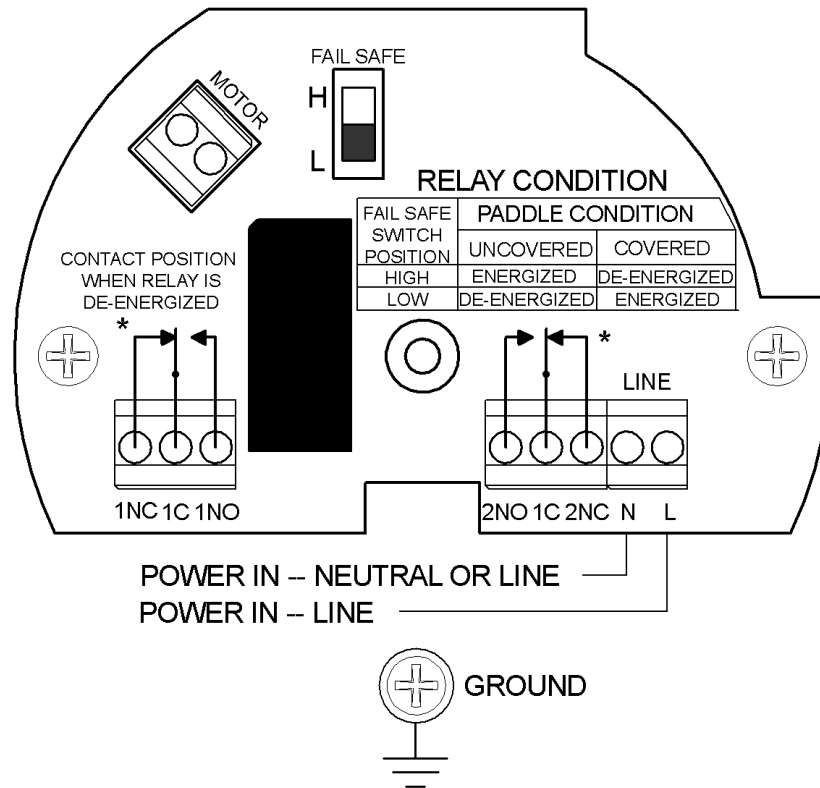



### 2.4 Grounding

An equipment grounding connection (earth ground) to the rotary is required for safety. Connect the ground conductor to the green grounding screw inside the enclosure.

### 3.0 DPDT RELAY

The DPDT relay utilizes a Fail Safe selector switch. There are two positions for the switch, High (H) and Low (L). A Fail Safe condition means the DPDT relay contact positions are set so in the event of a power failure the relay will be de-energized and the contacts will indicate a condition that is deemed safe for the application.

#### 3.1 Fail Safe High

Fail Safe High means that the relay will be energized when the paddle is rotating (uncovered) and will de-energize when the paddle is covered. In this mode, a power failure will cause the relay contacts to indicate that the paddle is covered, whether it is or not.

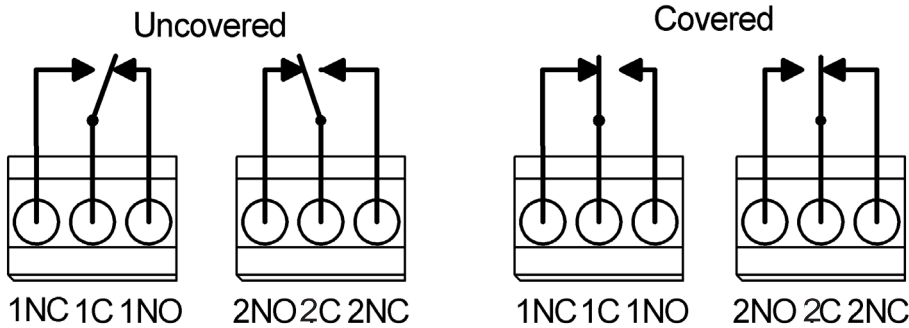

#### 3.2 Fail Safe Low

Fail Safe Low means that the relay will be de-energized when the paddle is rotating (uncovered) and will energize when the probe is covered. In this mode, a power failure will cause the relay contacts to indicate that the paddle is uncovered, whether it is or not.

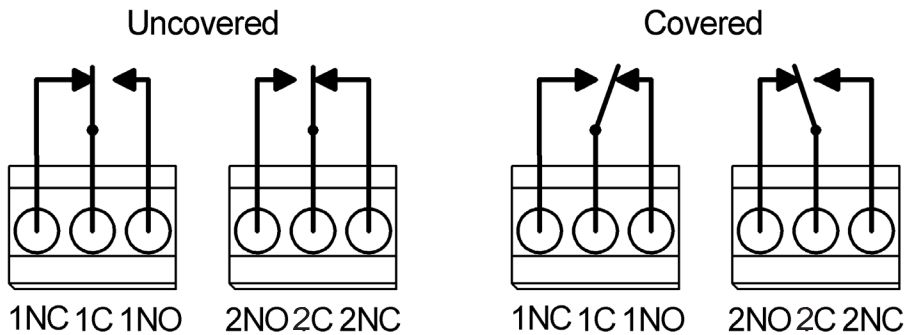

## 4.0 WARRANTY AND CUSTOMER SERVICE

### 4.1 Limited Warranty

**LIMITED PRODUCT WARRANTY.** Products manufactured by Seller are warranted for a period of one (1) year from date of shipment against defective materials and workmanship (the "Warranty Period"). SELLER MAKES NO OTHER WARRANTY, EXPRESS OR IMPLIED, AND ANY WARRANTY OF MERCHANTABILITY OR FITNESS FOR A PARTICULAR PURPOSE IS HEREBY DISCLAIMED AND EXCLUDED.

This limited warranty does not extend to labor charges or other costs related to the removal and/or replacement of defective products or services. Any technical advice or services furnished by Seller with respect to the products is given without charge, and Seller assumes no obligation or liability for the advice given or results obtained, all such advice being given and accepted at Buyer's sole risk and expense. If the products are being acquired for resale, Buyer will make, in connection with any such resale, only those warranties contained herein and will indemnify Seller and its officers, directors, agents, employees, affiliates, successors, and assigns against any claims, causes of actions and judgments which arise from any representations, warranties, or agreements made by or entered into by Buyer, other than those contained herein.

**WARRANTY EXCLUSIONS.** Notwithstanding Seller's Limited Product Warranty, products that have been or are (1) damaged by accident, corrosion, the elements, abuse, misuse, misapplication, vandalism, negligence, improper transportation, handling, storage, use or lack of proper and reasonable maintenance, (2) repaired or altered by anyone other than Seller or its authorized service providers, (3) modified or altered without Seller's written authorization, or (4) specially manufactured by Seller as per specifications provided by Buyer, are expressly excluded from Seller's Limited Product Warranty.

### 4.2 Customer Service

BinMaster's toll-free Customer Service phone number is 1-800-278-4241. Call the Technical Service Department for support Monday through Friday from 8:00 AM to 5:00 PM Central Time. International customers call 1-402-434-9102 or [techsupport@binmaster.com](mailto:techsupport@binmaster.com).

## 5.0 DISPOSAL

This product contains recyclable materials and electronics that can be easily separated and recycled by specialized recycling companies. Consult local authorities for proper disposal locations.



BinMaster: Division of Garner Industries LLC  
Lincoln, NE  
402-434-9102  
info@binmaster.com | www.binmaster.com