

DPM-400 Loop-Powered Meter Instruction Manual



- 1/8 DIN Loop-Powered Process Meters with NEMA 4X, IP65 Front
- 4-20 mA Input Displayed with $\pm 0.02\%$ FS Accuracy
- 1.5 Volt Drop (4.5 Volt Drop with Backlight)
- 0.7" (17.8 mm) 5 Alphanumeric Characters Top Display
- 0.4" (10.2 mm) 8 Alphanumeric Characters Bottom Display
- 20-Segment Bargraph with Numeric Percent Indication, Optional
- Shallow Depth Case Extends Only 3.6" (91 mm) Behind Panel
- (2) Open Collector Outputs Standard; Assigned to Pulse, Alarm, Timer, or Stopwatch
- (2) Optional Loop-Powered Solid State Relays; Assigned to Alarm, Control, Timer, or Stopwatch
- Stopwatch & Timer Functions to Drive Relays & Open Collectors
- Optional Isolated 4-20 mA Analog Output
- Relay Pump Alternation Based on Level and Runtime
- Display Relay Runtime & Cycle Count via Relay Info Menu
- Round Horizontal Tank Function; Just Enter Diameter & Length
- 32-Point Linearization, Square Root Extraction and Programmable Exponent Function
- Free PC-Based MeterView XL USB Programming Software
- HART® Protocol Transparent
- Loop-Powered Backlight with Red Backlight for Alarm Conditions
- Operating Temperature Range: -40 to 167°F (-40 to 75°C)
- Conformal Coated PCBs for Dust & Humidity Protection
- Password Protection
- NEMA 4X Enclosures for up to Ten Meters
- 3-Year Warranty

BINMASTER

Division of Garner Industries LLC
7201 North 98th Street, Lincoln, NE 68507 USA
Tel (800) 278-4241 • Fax: (402) 434-9133

www.binmaster.com

BINMASTER

Table of Contents

Introduction.....	5
Key Features	6
Ordering Information.....	8
Specifications	10
Display	10
General.....	10
Input	10
Common Open Collector & Relay (Alarm) Specifications	11
Open Collector Outputs.....	11
Solid State Relays	11
4-20 mA Transmitter Output.....	11
On-Board Digital Input.....	11
MeterView XL Programming Software.....	12
General Compliance Information	12
Electromagnetic Compatibility.....	12
EU Declaration of Conformity.....	13
Safety Information	13
Installation.....	14
Unpacking.....	14
Panel Mounting Instructions	14
MeterView XL Programming Software.....	15
MeterView XL Software Installation	15
Connecting to the Computer	15
Specifications.....	15
Dimensions	15
Connections.....	16
Connectors Labeling	16
Wiring Diagrams	17
Current Loop (4-20 mA) Connections	17
Digital Input Connection.....	17
4-20 mA Output Connections.....	17
Solid State Relay Connections.....	17
Open Collector Outputs	17
Setup and Programming.....	18
Overview	18
MeterView XL Programming Software.....	18
Front Panel Buttons and Status LCD Indicators	18
Display Functions & Messages.....	19
Main Menu.....	23
Setting Numeric Values	23
Scaling the 4-20 mA Input (INPUT).....	23
Available Unit Classes and Units	24
Setting Custom Units (CUSTOM).....	24
Setting the Display Features (DISPLAY).....	25
Changing the Engineering Units (UNITS).....	25
Changing the Decimal Point (DECP).....	25
Enabling or Disabling Commas on the Bottom Display (COMMA)	25
Display Capabilities Optimization (TOP and BOTTOM).....	25
Configuring the Display (TOP and BOTTOM).....	26
Programming the Bargraph (BARGRAPH).....	26
Programming the Outputs (OUTPUT).....	27
Open Collector Outputs (OPEN COLLECTR)	27
Solid State Relay Outputs (RELAY)	30
Isolated 4-20 mA Output (4-20 mA)	33
Output Manual Control (CONTROL).....	33

- Advanced Features Menu (ADVANCE)**..... 34
 - Advanced Process Variable Setup (ADV PV SETUP)..... 34
 - Low-Flow Cutoff (CUTOFF) 35
 - Noise Filter (FILTER) 35
 - Enabling Password Protection (PASSWORD) 35
 - Programmable Function Keys User Menu (USER) 36
 - Tare (TARE) 36
 - Changing System Settings (SYSTEM) 38
- Meter Operation**..... 40
 - Front Panel Buttons Operation** 40
 - Function Keys Operation**..... 40
 - Digital Input Operation**..... 40
 - Maximum/Minimum Readings**..... 40
 - Runtime & Cycle Count (INFO)**..... 41
 - Changing Engineering Units** 41
- Troubleshooting** 42
 - Reset Meter to Factory Defaults**..... 42
 - Determining Software Version** 42
 - Factory Default Settings..... 43
 - Troubleshooting Tips**..... 44

Table of Figures

Figure 1. 1/8 DIN Panel Cutout Dimensions	14
Figure 2. Panel Mounting Details	14
Figure 3. Meter Dimensions - Side View	16
Figure 4. Meter Dimensions - Front View	16
Figure 5. Connector Labeling for 348-0093	16
Figure 6. Connector Labeling for 348-0094	16
Figure 7. Connector Labeling for 348-0095	16
Figure 8. Connector Labeling for 348-0096	16
Figure 9. 4-20 mA Input Connection without Backlight	17
Figure 10. 4-20 mA Input Connection with Backlight	17
Figure 11. Digital Input Connections	17
Figure 12. 4-20 mA Output Connections	17
Figure 13. Solid State Relay Connections	17
Figure 14. Open Collector Output Connections.....	17

Disclaimer

The information contained in this document is subject to change without notice. BinMaster makes no representations or warranties with respect to the contents hereof; and specifically disclaims any implied warranties of merchantability or fitness for a particular purpose.

CAUTION

- Read complete instructions prior to installation and operation of the meter.

WARNINGS

- Risk of electric shock or personal injury.
- This product is not recommended for life support applications or applications where malfunctioning could result in personal injury or property loss. Anyone using this product for such applications does so at his/her own risk. BinMaster shall not be held liable for damages resulting from such improper use.

WARNING

Cancer and Reproductive Harm - www.P65Warnings.ca.gov

Limited Warranty

BinMaster warrants this product against defects in material or workmanship for the specified period under "Specifications" from the date of shipment from the factory. BinMaster's liability under this limited warranty shall not exceed the purchase value, repair, or replacement of the defective unit. See Warranty Information and Terms & Conditions on www.binmaster.com for complete details.

Registered Trademarks

All trademarks mentioned in this document are the property of their respective owners.

© 2024 BinMaster.
All rights reserved.

Introduction

These loop-powered 1/8 DIN digital panel meters can be installed virtually anywhere to provide convenient and informative display of any 4-20 mA signal. One of the most convenient features of these instruments is their dual line display which is typically used to display the process variable on the 5-digit alphanumeric top display and the units of measure or a tag on the 8-digit alphanumeric bottom display. Another common setup is to display the input in one scale on the top display (such as feet) and in another scale on the bottom display (such as gallons). Both display lines use 14-segment, alphanumeric characters for clear indication of tags, units, or alarm messages.

Further enhancing the display on these instruments is a 20-segment bargraph that also includes a numeric value of the percentage the bargraph represents. These loop-powered meters can be installed virtually anywhere because they get their power from the 4-20 mA loop and therefore require no separate power source. And they only drop 1.5 V (4.5 V with backlight), so they add very little burden to the loop. Additional features that allow these instruments to be installed virtually anywhere include a NEMA 4X, IP65 front panel, an operating temperature range of -40 to 167°F (-40 to 75°C), conformally coated PCBs, and a backlit LCD that can be read in bright sunlight or dimly lit areas.

Free, PC-based, MeterView XL software that connects to the meter via a micro USB cable is available for programming and setup of the meters.

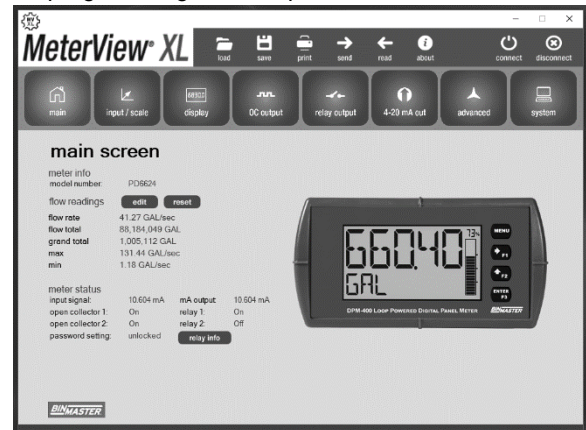

All models come equipped with two open collector outputs and a digital input. There are also models available with two solid state relays and isolated 4-20 mA analog output options. The open collector outputs are useful for alarm indication. The digital input can be used to acknowledge the relays, to start/stop a timer/stopwatch, and more. The relays can be programmed for alarm indication, on/off control, or pump alternation.

Key Features

DPM-400 Loop-Powered Meter with Bargraph

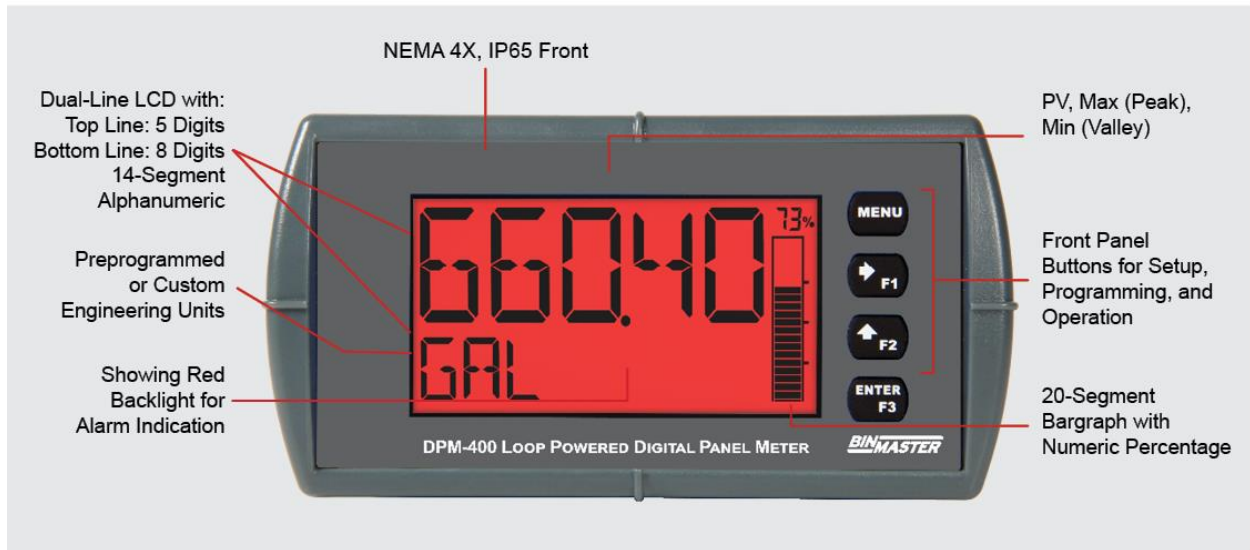

Informative Display

The DPM-400's display provides multiple ways to help users understand and keep track of their processes. The most obvious is the dual line which typically allows the user to display a numeric value of the process variable on the top line and units and/or a tag on the bottom line. An optional bargraph that includes a numeric value of the percentage the bargraph represents is also available.

Predefined display units give users even more display flexibility. Plus, the high contrast backlit LCD display is readable from far away and under various lighting conditions.

Alarm Indication

When an alarm occurs, the DPM-400's display can be programmed to turn red. It may also be set up to flash an alarm message along with the process variable. The flashing red alarm message can be activated even if no relay or open collector is connected.



Dual-Scale Feature

Users can use the dual-scale feature to display the input in two different scales. For instance, the example above shows an application where the display shows the input in feet and gallons while the display toggles between process values and units.

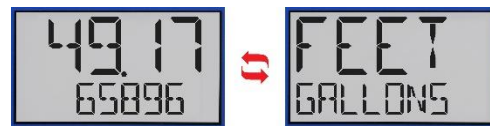

14-Segment Characters

Notice how much better letters like "T", "N" and "K" appear as 14-segment characters on the DPM-400 vs 7-segment characters found on many other meters.



Predefined and Custom Units

The meter has six available preprogrammed unit classes: volume, height, temperature, pressure, weight, and rate. When the desired unit class or unit of measure within a class is not available, a custom unit may be programmed.

Password Protection

A password can be set up for programming security to prevent unauthorized changes to the programmed parameter settings.

Multiple Outputs

- Two open collector outputs (standard)
- Two solid state relays (optional)
- One 4-20 mA output (optional)

The open collector outputs and relays generally operate in the same manner, with the major exception being the open collectors are not available for pump alternation and the relays are not available with pulse features. The open collectors and relays can be controlled either automatically or manually.

The isolated analog output signal can be configured to represent the process variable (PV1, PV2, or retransmit). It can also be reverse scaled such that the meter's high calibration value outputs 4 mA and the meter's low calibration outputs 20 mA.

Pump Alternation (ALTERN)

For pump control applications where two similar pumps are used to control the level of a tank or a well, it may be desirable to have the pumps operate alternately. This prevents excessive wear and overheating of one pump over the lack of use of the other pump. Pump alternation uses both relays in tandem to alternate between two similar pumps. The ALTERN menu is only available under Output 1 and will automatically set Output 2 to pump alternation as well.

Pump Alternation Example

The following is an example application where the relays are programmed for pump alternation.

On & Off Point Programming			
Relay	On Point	Off Point	Function
1	7000	1000	Controls backup pump
2	6000	1000	Controls main pump

The following graphics provide a visual representation of a typical pump alternation application:

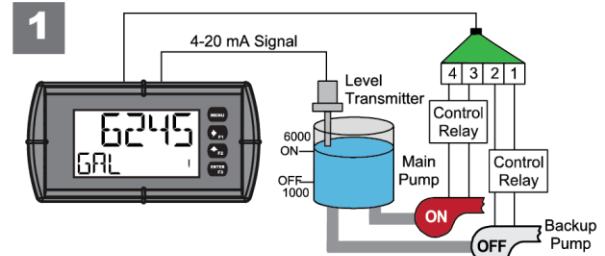

Relay #2 turns the main pump on at 6000 gallons and turns it off at 1000 gallons.

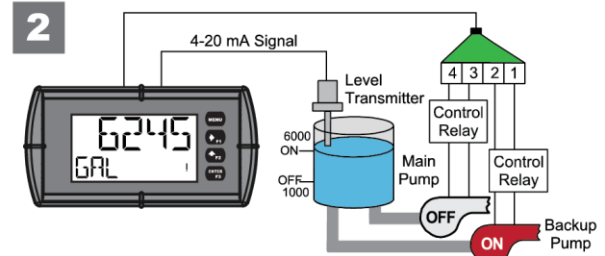

With the Pump Alternation feature activated, the next time the level reaches 6000 gallons, relay #1 transfers and starts the backup pump.

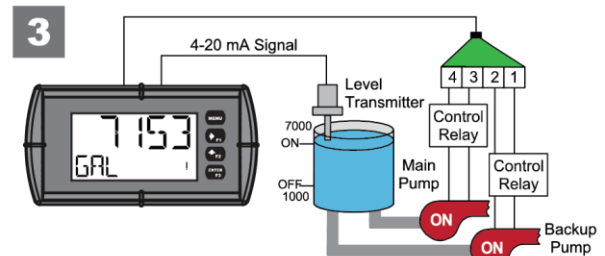

If the backup pump is not able to keep up, and the level reaches 7000 gallons, relay #2 transfers and starts the main pump as well.

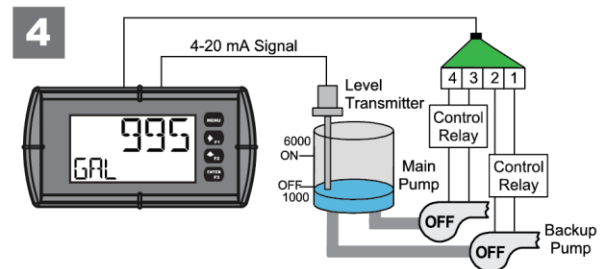

Once the level has dropped below the reset points, both relays will turn off.

Note: Open Collectors can be used for high and low alarm indication

Ordering Information

DPM-400 • Decimal Display/Bargraph Models	
Model	Description
348-0093	Decimal Display, Bargraph, No Options
348-0094	Decimal Display, Bargraph, Two Solid State Relays
348-0095	Decimal Display, Bargraph, 4-20 mA Analog Output
348-0096	Decimal Display, Bargraph, Two Solid State Relays and 4-20 mA Analog Output

Note: All models come with two open collector outputs and one digital input standard.

Accessories

Model	Description
PDA18DINSH	Stainless Steel Sun Hood

Stainless Steel Sun Hood Accessory



The PDA18DINSH Sun Hood improves the readability of 1/8 DIN digital panel meters when they are mounted in direct sunlight by shading the instrument from the sun.

The Sun Hood is made from 18 gauge 316 stainless steel and mounts between the 1/8 DIN digital panel meter and the panel. In addition, a gasket is provided that installs between the Sun Hood and the panel to provide a NEMA 4X seal to the panel. The whole assembly is held in place by the panel meter's mounting brackets.

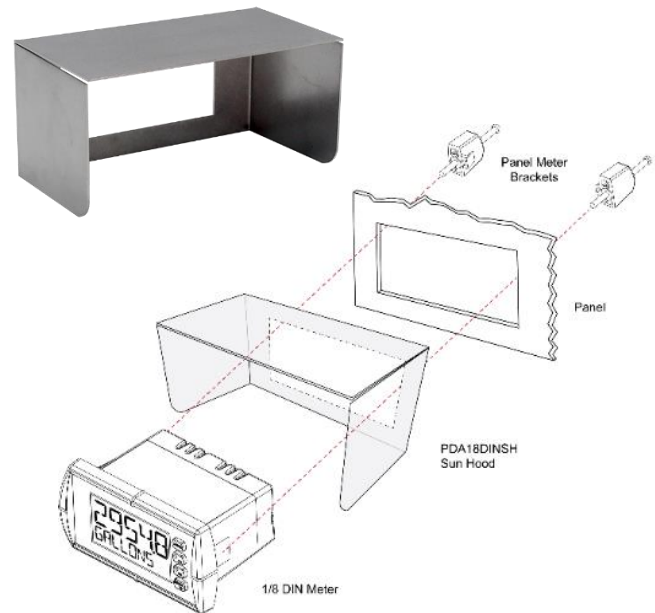

Enclosures

Model	Description
220-0445	1 Meter Plastic NEMA 4X Enclosure
220-0446	2 Meter Plastic NEMA 4X Enclosure
220-0447	3 Meter Plastic NEMA 4X Enclosure
220-0448	4 Meter Plastic NEMA 4X Enclosure
220-0449	5 Meter Plastic NEMA 4X Enclosure
220-0444	6 Meter Plastic NEMA 4X Enclosure
220-0450	7 Meter Plastic NEMA 4X Enclosure
220-0451	8 Meter Plastic NEMA 4X Enclosure
220-0452	9 Meter Plastic NEMA 4X Enclosure
220-0453	10 Meter Plastic NEMA 4X Enclosure



220-0445



220-0446



220-0447



220-0448



220-0449



220-0444



220-0450



220-0451



220-0452



220-0453

Specifications

Except where noted all specifications apply to operation at +25°C.

Display

Display	Dual-line LCD with backlight. Both lines 14-segment alphanumeric. Top: 0.7" (17.8 mm) Bottom: 0.4" (10.2 mm) Display may be programmed to turn red and flash a user-defined message on alarm condition.
Backlight	Powered by 4-20 mA loop Intensity varies with signal level
Top Display	5 digits (-9999 to 99999) or 5 characters (all capital & most lower-case letters)
Bottom Display	8 digits (-9,999,999 to 99,999,999; separated by commas) or 8 characters (all capital & most lower-case letters)
Bargraph	20 segments, numeric percent indication at top
Decimal Point	Up to four decimal places on top display and up to seven decimal places on bottom display
Commas	Commas to indicate 1000s (e.g. 88,987,628) on bottom display
Dual-Scale Feature	The input can be displayed in different scales on the top and bottom displays. For instance, the top display could display the input in height and the bottom display could display that same input in volume.
Alarm Indication	Programmable: red backlight, flashing display, Bargraph segment flashes on alarm.
Alarm Message	Programmable: 8 characters maximum; displayed every 10 sec for 1 sec on bottom display. May be turned off.
Display Update Rate	Ambient > -10°C: 1 Update/Second Ambient = -20°C: 1 Update/2 Seconds From -20°C to -40°C the update rate slows down 1 second for every -2°C (e.g. at -24°C, 1 update/4 seconds).
Overrange	Top: 99999; Bottom: 99,999,999 (flashing)
Underrange	Top: -9999; Bottom: -9,999,999 (flashing)

General

Programming Method	Front panel & Free PC-based USB programming software
Enclosure & Materials	Enclosure: 1/8 DIN, IP65, NEMA 4X front panel, high impact plastic, NORYL® polyphenylene ether & polystyrene blend (PPE PS) resin, UL 94V-0, Color: gray Gasket: silicone rubber Faceplate: LEXAN® polycarbonate (PC) Film Buttons: silicone rubber
Environmental	<i>Operating temperature range:</i> -40 to 75°C <i>Storage temperature range:</i> -40 to 85°C <i>Relative humidity:</i> 0 to 90% non-condensing; Printed circuit boards are conformally coated.
Noise Filter	Averages the input signal over a period of time between 1 and 16 seconds to dampen the effects of a noisy signal that causes a jumpy display.
Filter Bypass	0.0 to 99.9% of full scale. Input signal changes that are greater than bypass value are displayed immediately.
Recalibration	Recalibration is recommended at least every 12 months.

Max/Min Display	Max/min readings reached by the process are stored until reset by the user or until power to the meter is turned off.
Tare	Tare function zeros out the meter to accommodate for weight of a container. Tare function can be assigned to a function key or a digital input.
Password	Programmable password restricts modification of programmed settings.
Non-Volatile Memory	All programmed settings are stored in non-volatile memory for a minimum of ten years if power is lost.
Normal Mode Rejection	64 dB at 50/60 Hz
Connections	Removable screw terminals accept 12 to 22 AWG wire
Tightening Torque	<i>Screw terminal connectors:</i> 4.5 lb-in (0.5 Nm) <i>Mounting screws:</i> 8.0 lb-in max. (0.9 Nm)
Overall Dimensions	4.68" x 2.45" x 3.79" (119 mm x 62 mm x 96 mm) (W x H x D)
Weight	8.7 oz (247g) with option board
Warranty	3 years parts and labor. See Warranty Information and Terms & Conditions on www.binmaster.com for complete details.

Input

Input	4-20 mA
Accuracy	±0.02% of span ±1 count, Square root and programmable exponent: 10-100% FS
Voltage Drop	Without backlight: 1.5 V maximum, With backlight: 4.5 V maximum
Equivalent Resistance	With backlight off: 75 Ω @ 20 mA With backlight on: 225 Ω @ 20 mA
Input Overload	Over current protection to 1 A maximum, Over voltage protection to 30 VDC max (between mA+ and mA-/BL-)
Temperature Drift	25 PPM/°C from -40 to 75°C ambient
Function	PV1: Linear (2-32 points), square root, or programmable exponent PV2: Linear (2-32 points) or round horizontal tank
Low-Flow Cutoff	0.1 to 999,999 or disable. Point below at which the display always shows zero.
HART Transparency	The meter does not interfere with existing HART communications; it displays the 4-20 mA primary variable and it allows the HART communications to pass through without interruption. The meter is not affected if a HART communicator is connected to the loop. The meter does not display secondary HART variables.

Common Open Collector & Relay (Alarm) Specifications

Number	Two open collectors & two relays
High or Low Alarm	User programmable for high or low alarm
Alarm Deadband	0-100% FS, user programmable
Output Assignment	Pulse, Alarm, Timer, Stopwatch, or Disable
Alarm Output Source	Assign to PV (PV1, PV2) or Digital Input
On & Off Time Delay	0 to 9,999 seconds
Fail-Safe Operation	Independent for each open collector and relay. Fail-safe on, the output is on under normal conditions. Fail-safe off, the output is on under alarm conditions.
Alarm Operation	Automatic, automatic with manual override, latching (manual reset anytime), latching with reset after cleared (manual reset only after alarm has cleared)
Alarm Indication	Programmable: red backlight, flashing display, alarm symbol (!); (symbols not available on bargraph models). Bargraph segment flashes on alarm.
Alarm Message	Programmable: 8 characters maximum; displayed every 10 sec for 1 sec on bottom display. May be turned off.
Alarm Acknowledge	Front panel ACK button or external digital input resets output and screen indication.
Auto Initialization	When power is applied to the meter, open collectors and relays will reflect the state of the input to the meter.
Timer Output	One-shot or Continuous Off Time Delay: 1 sec to 99:59:59 (hrs:min:sec) On Time: 1 sec to 99:59:59 (hrs:min:sec)
Stopwatch	Output turns on when started and off when stopped.

Open Collector Outputs

Rating	Isolated open collector, sinking NPN 5-30 VDC @ 150 mA maximum
Output Assignment	Pulse, Alarm, Timer, Stopwatch, or Disable
Pulse Output Source	PV (PV1, PV2) or Test Frequency
Pulse Output Factor	0.000001 to 999,999.9
Pulse Width	0.5 ms @ 1 kHz; 500 ms @ 1 Hz; 50% duty cycle
Pulse Output Frequency	1,000 Hz maximum
Quadrature Pulse Output	Available for Output 2 (90° behind Output 1) 500 Hz max
Alarm Output Source	Assign to PV (PV1, PV2) or Digital Input

Solid State Relays

Rating	250 VAC/VDC @ 1 A resistive 75 VA; 250 VAC; 0.6 A pilot duty (inductive) – UL Code D300 25 VA; 250 VDC; 0.6 A pilot duty (inductive) – UL Code R300
Noise Suppression	Metal oxide varistors across outputs
Relay Assignment	Pump Alternation, Alarm, Timer, Stopwatch on/off, or Disable
Alarm Output Source	Assign to PV (PV1, PV2) or Digital Input
Pump Alternation	Relays may be programmed to alternate with each pump cycle with an elapsed time override where the pumps will alternate regardless of level. Pump alternation time can be programmed for 0 to 999:59 (hrs:min)
Relay (Pump) Runtime	Meter will keep track of how long each relay (pump) has operated and display this information.
Relay (Pump) Cycles	Meter will keep track of how many times the relays (pumps) have cycled and display this information.

4-20 mA Transmitter Output

Accuracy	±0.05% FS ±0.001mA
Output Source	PV1, PV2, re-transmit; reverse scaling allowed
Scaling Range	1.00 to 23.0 mA
Disable	High impedance state, less than 1 mA
Calibration	Factory calibrated 4.00 to 20.00 mA
Underrange	1.0 mA, 3.5 mA, or 3.8 mA (If input < 3.5 mA); or disable underrange; user selectable
Overrange	20.5 mA, 20.8 mA, or 23.0 mA (If input > 20.5 mA); or disable overrange; user selectable
Isolation	500 V input-to-output
Temperature Drift	0.5 µA/°C max from -40 to 75°C ambient
External Loop Power Supply	7.0 VDC to 30.0 VDC maximum
Output Loop Resistance	10-750 Ω @ 24 VDC; 10-1100 Ω @ 30 VDC

On-Board Digital Input

Function	Remote operation of front-panel buttons, acknowledge/reset relays, reset max/min values, etc. See User section of <i>Display Functions & Messages</i> on page 18 for a complete list of capabilities.
Contacts	2.1 VDC on contact. Connect normally open contacts across DI+ and DI-
Logic Levels	Logic High: 2.4 to 30 VDC (max) Logic Low: 0 to 0.9 VDC

MeterView XL Programming Software

Availability	Free download from meter
System Requirements	Microsoft® Windows® 10 & 11
Communications	USB 2.0 (Standard USB A to Micro USB B)
Configuration	Configure all parameters on the meter. Configure meters one at a time.
Configuration Files	Generate with or without meter connected; Save to file for later use.
USB Power Connection	Meter is powered by USB connection during programming, if 4-20 mA loop is not connected.

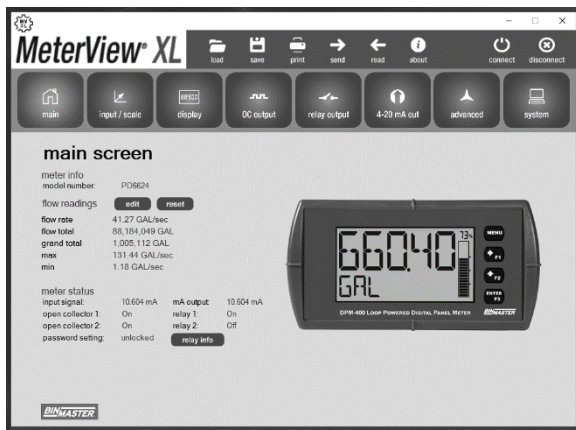

General Compliance Information

Electromagnetic Compatibility

- EMC Emissions**
- CFR 47 FCC Part 15 Subpart B Class A emissions requirements (USA)
 - AS/NZS CISPR 11 Class A ISM emissions requirements (Australia)
 - EN 55011 Group 1 Class A ISM emissions requirements (EU)
 - ICES-001 Issue 4 ISM emissions requirements (Canada)

EMC Emissions and Immunity EN 61326-1
EMC requirements for Electrical equipment for measurement, control, and laboratory use – Industrial Use

EU Declaration of Conformity

For shipments to the EU and UK, a Declaration of Conformity is available online at predig.com/docs.

Safety Information

CAUTION

- Read complete instructions prior to installation and operation of the meter.

WARNINGS

- Risk of electric shock.
 - Hazardous voltages exist within enclosure.
 - Installation and service should be performed only by trained service personnel
 - Service requiring replacement of internal components must be performed at the factory.
-

Installation

There is no need to remove the meter from its case to complete the installation, wiring, and setup of the meter for most applications.

Unpacking

Remove the meter from box. Inspect the packaging and contents for damage. Report damages, if any, to the carrier.

If any part is missing or the meter malfunctions, please contact your supplier or the factory for assistance.

Panel Mounting Instructions

- Prepare a standard 1/8 DIN panel cutout – 3.622" x 1.772" (92 mm x 45 mm). Refer to *Figure 1* and *Figure 2* below, for more details.
- Clearance: allow at least 4.0" (102 mm) behind the panel for wiring.
- Panel thickness: 0.04" - 0.25" (1.0 mm - 6.4 mm). Recommended minimum panel thickness to maintain Type 4X rating: 0.06" (1.5 mm) steel panel, 0.16" (4.1 mm) plastic panel.
- Remove the two mounting brackets provided with the meter (back-off the two screws so that there is ¼" (6.4 mm) or less through the bracket. Slide the bracket toward the front of the case and remove).
- Insert meter into the panel cutout.
- Install mounting brackets and tighten the screws against the panel. To achieve a proper seal, tighten the mounting bracket screws evenly until meter is snug to the panel along its short side. **DO NOT OVER TIGHTEN**, as the rear of the panel may be damaged.

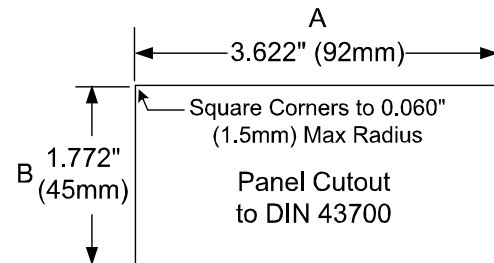

Tolerances:

A: +0.032 (+0.8mm)

-0.000 (-0.0mm)

B: +0.024 (+0.6mm)

-0.000 (-0.0mm)

Figure 1. 1/8 DIN Panel Cutout Dimensions

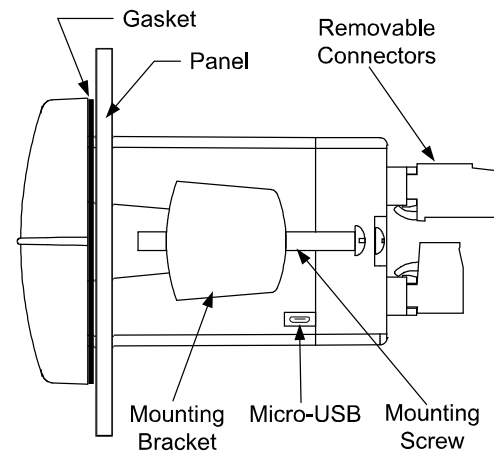

Figure 2. Panel Mounting Details

MeterView XL Programming Software



Free, PC-based, MeterView XL software that connects to the meter via a USB cable is available for programming and setup of the meters. This software greatly simplifies the programming process and allows the user to save configuration files for later use. The meter will also be powered by the USB connection so no additional power is needed during programming.

- Free PC-Based USB Programming Software
- Easy Programming of Feature-Packed Product
- USB Connection Provides Power to the Meter During Programming
- Save & Print Configuration Files without Meter Connected
- USB Cable Provided with Meter
- PC Data Logging for One or Multiple Variables

MeterView XL Software Installation

⚠ IMPORTANT

- Please uninstall previous versions of this software prior to downloading, installing, and running the latest version.

1. Connect one end of the provided USB cable to the meter and the other end to the computer.
The computer will automatically install the driver software it needs to talk to the meter. Follow the on-screen instructions and allow sufficient time for the process to complete. This can take a few minutes. If the process is interrupted, then it could leave the system in an unstable condition.
2. Double-click MeterView XL Windows Installer Package file to open.
3. The MeterView XL Setup Wizard window will appear. Click “Next” to start the installation process.
4. The MeterView XL License Agreement window appears next. Select “I agree” and click “Next” to continue the installation process.
5. Choose the folder location where you would like the software to be installed to and select

options for use. Then click “Next” to continue.

6. Confirmation window will appear. Click “Next” to confirm the installation.
7. The User Account Control message is displayed. Click “Yes” to proceed with the installation.
8. Finally, the Installation Complete window will appear. Click “Close” to exit.

Now you are ready to open the MeterView XL software to begin programming your DPM-400 meter.

Connecting to the Computer

DPM-400 series meters may be connected to any Windows 10 or Windows 11 PC via the provided USB cable by following these steps:

1. Open the MeterView XL software.
2. Connect the DPM-400 meter to the PC with the provided USB cable.
3. The software will ask if you would like to read the meter. Click OK.

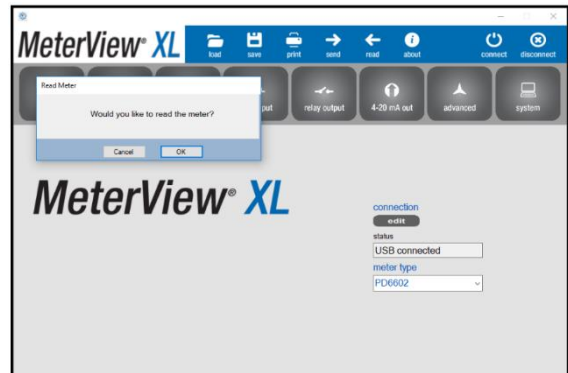

Specifications

Availability	Download directly from meter
System Requirements	Microsoft® Windows® 10 & 11
Communications	USB 2.0 (Standard USB A to USB B)
Configuration	Configure all parameters on the meter. Configure meters one at a time.
Configuration Files	Generate with or without meter connected; Save to file for later use.
USB Power Connection	Meter is powered by USB connection during programming, if 4-20 mA loop is not connected.

Dimensions

All units: inches (mm)

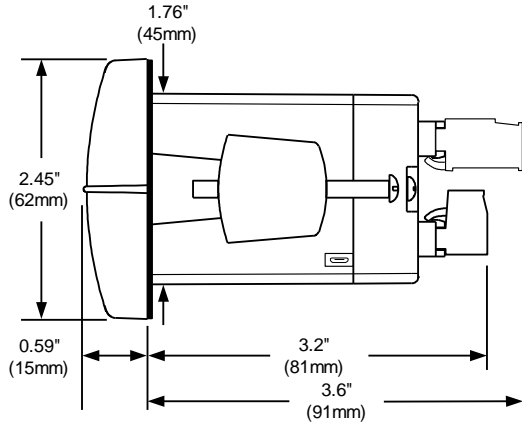

Figure 3. Meter Dimensions - Side View

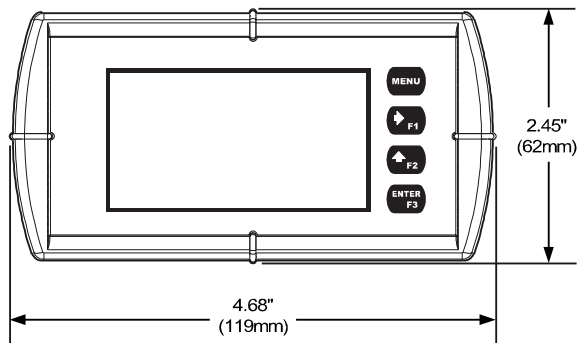

Figure 4. Meter Dimensions - Front View

CAUTION

- Use copper wire with 60°C or 60/75°C insulation for all line voltage connections. Observe all safety regulations. Electrical wiring should be performed in accordance with all applicable national, state, and local codes to prevent damage to the meter and ensure personnel safety.

Connections

All connections are made to removable screw terminal connectors located at the rear of the meter.

Connectors Labeling

The graphics below show the location of all connectors available with requested configuration.

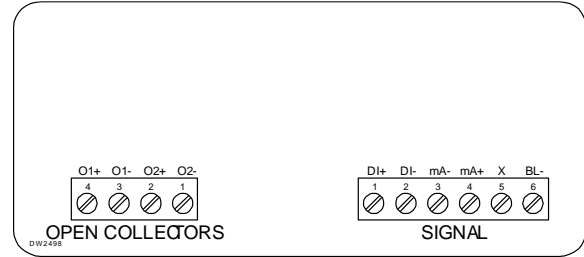

Figure 5. Connector Labeling for 348-0093

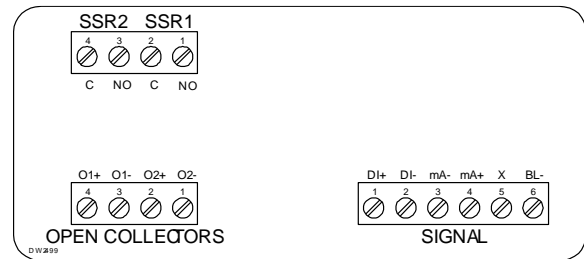

Figure 6. Connector Labeling for 348-0094 with 2-Solid State Relays

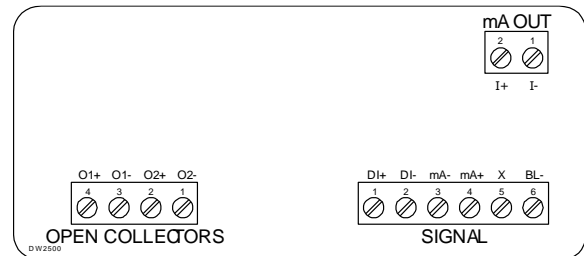

Figure 7. Connector Labeling for 348-0095 with 4-20 mA Output

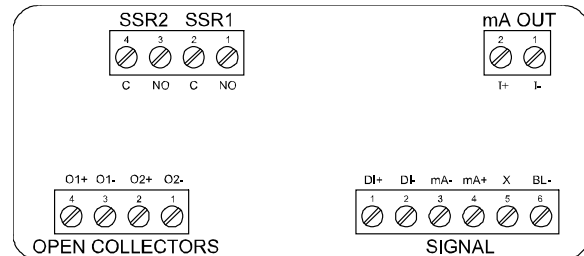

Figure 8. Connector Labeling for 348-0096 with 2 Solid State Relays & 4-20 mA Output

Wiring Diagrams

Current Loop (4-20 mA) Connections

Signal connections are made to a six-terminal connector labeled SIGNAL. See *Connectors Labeling* on page 16. The following figures show a 4-20 mA current loop connected to the meter. *Figure 9* shows the connection without the backlight and *Figure 10* shows the connection with the backlight (the backlight can be disabled/enabled in the SYSTEM menu). The meter is powered by the 4-20 mA current loop.

There are no switches or jumpers to set up for the input. Setup and programming is performed through the front panel buttons or PC-based software.

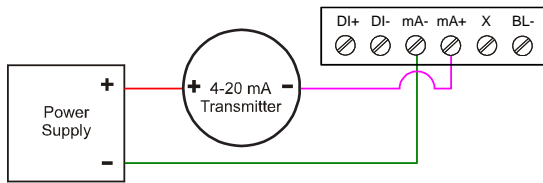

Figure 9. 4-20 mA Input Connection without Backlight

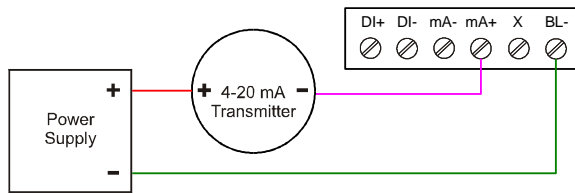

Figure 10. 4-20 mA Input Connection with Backlight

The current input is protected against current overload up to 1 amp. The display may or may not show a fault condition depending on the nature of the overload.

Digital Input Connection

A digital input is standard on the meter. This digital input is connected with a normally open contact across DI+ and DI-, or with an active low signal applied to DI+ and DI-.

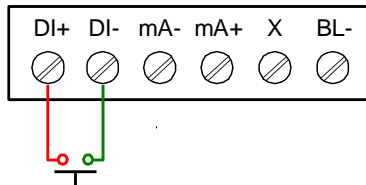

Figure 11. Digital Input Connections

4-20 mA Output Connections

Connections for the 4-20 mA transmitter output are made to the connector terminals labeled mA OUT. The 4-20 mA output must be powered from an external power supply.

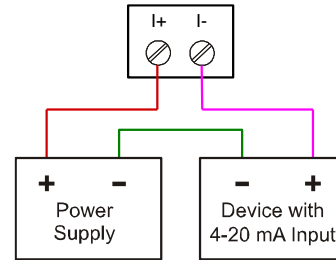

Figure 12. 4-20 mA Output Connections

Solid State Relay Connections

Relay connections are made to a four-terminal connector labeled SSR1 and SSR2 on *Figure 6*. See *Connector Labeling for 348-0094 with 2-Solid State Relays* and *Figure 8*. See *Connector Labeling for 348-0096 with 2 Solid State Relays & 4-20 mA Output* on page 16. Each relay's C terminal is common only to the normally open (NO) contact of the corresponding relay.

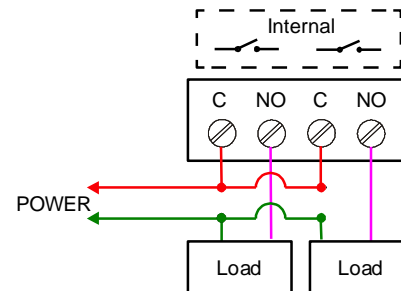

Figure 13. Solid State Relay Connections

Open Collector Outputs

Open collector output 1 and 2 connections are made to terminals labeled O1+ and O1-, and O2+ and O2-. Connect the alarm or pulse input device as shown below.

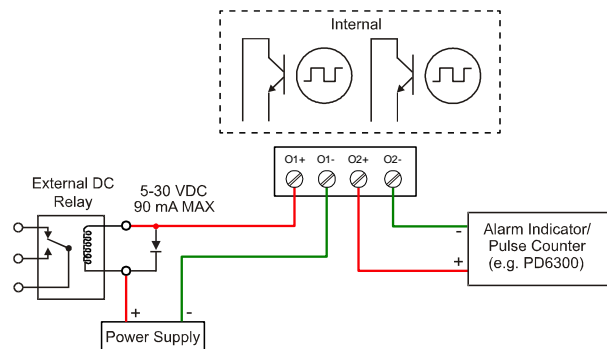

Figure 14. Open Collector Output Connections

Setup and Programming

The meter is factory calibrated prior to shipment to display 0.00 to 100.00, which corresponds to the 4-20 mA input. The calibration equipment is traceable to NIST standards.

Overview

There are no jumpers to set; setup and programming is done through the front panel buttons or PC-based software.

The meter may be powered via the micro-USB connection located on the right side of the meter for the purposes of programming only. The backlight will not work while the meter is powered via the USB connection.

MeterView XL Programming Software

The fastest and easiest way to program the meter is using the free MeterView XL programming software. This software greatly simplifies the programming process and allows the user to save configuration files for later use.

The meter connects to the PC via a provided micro-USB cable and is powered by the USB connection, so no additional power is needed during programming.

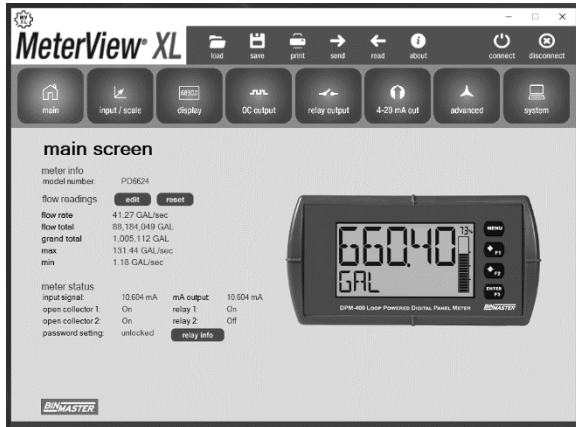

CAUTION

- Care should be exercised to avoid ground loops when connecting the USB to an active loop (e.g. power supply, transmitter, loop-powered meter, etc.). It is recommended to connect the (mA+) terminal of the meter to the (-) terminal of a two-wire transmitter and the (mA-) to the (+) of the next device in the loop or to the (-) terminal of the power supply.

Front Panel Buttons and Status LCD Indicators

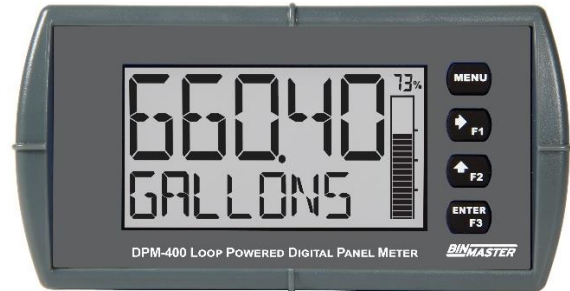

Button Symbol	Description
	Menu
	Right-Arrow/F1
	Up-Arrow/F2
	Enter/F3

LCD	Status
	PV Bargraph

- Press the **Menu** button to enter or exit the Programming Mode at any time.
- Press or hold the **Right-Arrow** button to scroll forward through the menus, select digits during numeric programming, select characters during text programming, or decrement the value of a digit or character selected with the **Up-Arrow** button.
- Press and hold the **Right-Arrow** button to zero or clear digits/characters while in data-entry mode.
- Press or hold the **Up-Arrow** button to scroll backwards through the menus or to increment the value of a digit or character.
- Press the **Enter** button to access a menu or to accept a setting or programmed digit/character value.

Display Functions & Messages

The meter displays various functions and messages during setup, programming, and operation. The following table shows the main menu functions and messages in the order they appear in the menu.

Display Functions & Messages	
Parameter	Action/Setting Description
INPUT (PV 1 and PV 2)	Program the meter 4-20 mA input (two menus, PV 1 and PV 2, are available if in dual-scale mode; see PV 2 under advanced features menu)
SCALE PV (1 or 2)	Scale the selected PV
UNITS	Select the display units
VOLUME	Volume unit class
GAL	Gallons
L	Liters
IGAL	Imperial Gallons
M3	Cubic Meters
BBL	Barrels
BUSH	Bushels
cuyd	Cubic Yards
cufL	Cubic Feet
cuin	Cubic Inches
L.BBL	Liquid barrels
BBBL	Beer barrels
HECEL	Hectoliter
AF	Acre-Foot
CUSTOM	Custom Unit
HEIGHT	Height unit class
INCH	Inches
FEET	Feet
YARD	Yards
CM	Centimeters
M	Meters
CUSTOM	Custom unit
TEMP	Temperature unit class
oF	Degrees Fahrenheit
oC	Degrees Celsius
K	Kelvin
oRA	Degrees Rankine
PRESSURE	Pressure unit class
PSI	Pounds per square inch
InHg	Inches of mercury
InH2O	Inches of water
mmHg	Millimeters of mercury
kg/cm2	Kilograms per square centimeter
kg/m2	Kilograms per square meter
mBar	Millibar

Display Functions & Messages	
Parameter	Action/Setting Description
BAR	Bar
PA	Pascal
hPA	Hectopascal
kPA	Kilopascal
MPA	Megapascal
CUSTOM	Custom unit
WEIGHT	Weight unit class
gm	Grams
kg	Kilograms
tonnE	Tonnes (metric)
oz	Ounces
lb	Pounds
ton	Tons
CUSTOM	Custom unit
RATE	Rate unit class
/SECOND	Units per second
/MINUTE	Units per minute
/HOUR	Units per hour
/DAY	Units per day
GAL/(T)	Gallons per time unit (T)
L/(T)	Liters per time unit (T)
IGAL/(T)	Imperial gallons per time unit (T)
M3/(T)	Cubic meters per time unit (T)
BBL/(T)	Barrels per time unit (T)
BUSH/(T)	Bushels per time unit (T)
cuyd/(T)	Cubic Yards per time unit (T)
cufL/(T)	Cubic Feet per time unit (T)
cuin/(T)	Cubic Inches per time unit (T)
L.BBL/(T)	Liquid barrels per time unit (T)
BBBL/(T)	Beer barrels per time unit (T)
HECEL/(T)	Hectoliter per time unit (T)
AF/(T)	Acre-Foot per time unit (T)
CUSTOM/	Custom unit per time unit (T)
CUSTOM	Custom unit class
CUNIT	Custom unit
INPUT 1	Program input 1 value
INP 1	Enter the input 1 value
DISP 1	Program display 1 value
ISP 1	Enter the display 1 value
INPUT 2	Program input 2 value (up to 32 points)
INP 2	Enter the input 2 value
DISP 2	Program display 2 value (up to 32 points)
ISP 2	Enter the display 2 value
SAVE?	Save programmed units, input, and display values

Display Functions & Messages	
Parameter	Action/Setting Description
OUTPUT	Program the meter's available outputs
OPEN COLLECTR	Program the meter's open collector outputs
OUTPUT 1	Open collector 1 setup
OUTPUT2	Open collector 2 setup
DISABLE	Disable the open collector
PULSE	Program the open collector for pulse output
ALARM	Program the open collector for alarm output
TIMER	Program the open collector as a timer
STOPWATCH	Program the open collector to turn on while the stopwatch is running
RELAY	Program the meter's relay outputs
OUTPUT 1	Relay 1 setup
OUTPUT2	Relay 2 setup
DISABLE	Disable the relay
ALARM	Program relay for alarm functionality
PUMPCTRL	Program relay for pump control application
TIMER	Program relay as a timer
STOPWATCH	Program relay to turn on while the stopwatch is running
RELAY INFO	View relay runtime and cycle count
4-20 mA	Program the meter's 4-20 mA output
PV	Program a range to transmit based on the display value
RETRANS	Retransmit the mA input signal
DISABLE	Disable the 4-20 mA output
CONTROL	Program manual or automatic operation for the outputs
OC 1	Open collector 1
OC2	Open collector 2
RELAY 1	Relay 1
RELAY2	Relay 2
4-20 mA	4-20 mA output
AUTO	Set selected output to automatic operation
MANUAL	Manually control selected output operation
ADVANCED	Program the meter's advanced features
PV SETUP (PV 1 & PV 2)	Advanced input programming (two menus, PV 1 and PV 2, are available if in dual-scale mode; see PV 2 under advanced features menu)

Display Functions & Messages	
Parameter	Action/Setting Description
SOURCE	Select PV 2 source (dual-scale only; see PV 2 under advanced features menu)
4-20 mA	Source PV 2 from the mA input
PV 1	Source PV 2 from PV 1
FUNCTION	Select linear, square root, or programmable exponent function
LINEAR	Set meter for linear function and select number of linearization points
SQROOT	Set meter for square root extraction
EXPONENT	Set meter for programmable exponent and enter exponent value
RM TANK	Round horizontal tank (dual-scale only; see PV 2 under advanced features menu)
SCALECAL	Scale or calibrate the mA input
SCALE PV	Scale the input
CAL PV	Calibrate the input
CUTOFF	Set low-flow cutoff
DISABLE	Disable low-flow cutoff
ENABLE	Enable low-flow cutoff
FILTER	Set noise filter value
10 SEC	1 second
20 SEC	2 seconds
40 SEC	4 seconds
80 SEC	8 seconds
160 SEC	16 seconds
OFF	Turn filter off
BYPASS	Set filter bypass (0.0 to 99.9% FS)
PASSWORD	Set a password for the meter
PASS MAIN	Program the main meter password
USER	Assign function keys / digital input
F 1	Assign F1 function key
F 2	Assign F2 function key
F 3	Assign F3 function key
DI	Assign digital input
DISP FN	Set the function key or digital input to display a value
DISPLAY	Cycle max, min, and PV(s)
DISP PV	Display the PV
PCT PV	Display the PV's percentage of max (20 mA)
UNITS	Display the PV's units
TAG	Display the PV's tag
DISPMIN	Display the PV's minimum value
DISPMAX	Display the PV's maximum value

Display Functions & Messages	
Parameter	Action/Setting Description
MIN MAX	Display the PV's minimum and maximum value
Ⓜ mA IN	Display the current mA input value
Ⓜ mA OUT	Display the current mA output value
MENU FN	Set the function key or digital input to access a menu
RLY INFO	Go to relay information menu (INFO)
MANCTRL	Go to output control menu (CONTROL)
TIMR DC 1	Open collector 1 timer
TIMR DC2	Open collector 2 timer
TIMER R 1	Relay 1 timer
TIMER R2	Relay 2 timer
TIMERFN	Set the function key or digital input to start or stop a timer
STARTALL	Start all timers
STOPALL	Stop all timers
SSTPALL	Start or stop all timers
DC 1	Start/stop open collector 1 timer
DC2	Start/stop open collector 2 timer
RLY 1	Start/stop relay 1 timer
RLY2	Start/stop relay 2 timer
START	Start the selected timer output
STOP	Stop the selected timer output
STR--STP	Start or stop the selected timer output
ALARMFN	Set the function key or digital input to acknowledge an alarm or access set points
ACK	Acknowledge all active alarms
SETPOINT	Access all output set points
SETPDC 1	Access open collector 1 set point
SETPDC2	Access open collector 2 set point
SETPTR 1	Access relay 1 set point
SETPTR2	Access relay 2 set point
SWATCHFN	Set the function key or digital input to activate stopwatch
START	Start the stopwatch
STOP	Pause/Stop the stopwatch
STR--STP	Start or stop the stopwatch
TAREFN	Set the function key or digital input to tare the display
TARE	Tare the display value
RST TARE	Reset the display value
HOLD FN	Set the function key or digital input to hold an output
HOLD OUT	Hold all outputs
HL UNHLD	Hold or un-hold all outputs

Display Functions & Messages	
Parameter	Action/Setting Description
DC 1+2	Hold/un-hold open collector outputs
RLY 1+2	Hold/un-hold relay outputs
mA OUT	Hold/un-hold 4-20 mA output
HOLD	Hold selected output
HL UNHLD	Hold or un-hold selected output
DISABLE	Disable function key or digital input
RST FN	Set the function key or digital input to reset a value
RESET	Reset min, max, or max/min PV
R MINMAX	Reset max and min PV value
HINT	Display hint text on key press and execute action on next key press
OFF	Turn the hint function off
ON	Turn the hint function on
SYSTEM	Program system settings
ADJCAL	Calibrate the analog output
DEFAULT	Reset meter to factory defaults
PV 2	Enable the meter to scale a second PV based on the same 4-20 mA input
DISABLE	Disable dual-scale feature (default)
ENABLE	Enable dual-scale feature
BACKLITE	Enable/disable display backlight
ENABLE	Enable the backlight (default)
DISABLE	Disable the backlight
INFO	View meter software version and model; change the identifier tag
SFT	The software ID number
VER	The software version
MODEL	The meter model number
IDTAG	The meter identifier tag Press <i>Enter</i> to edit tag
ICAL	Internal calibration used for scaling
DISPLAY	Program the meter's display
UNITS	Change the display units within the selected unit class
DECP	Change the decimal point location
COMMA	Enable or disable the use of a comma on the bottom display
ENABLE	Enable comma (default)
DISABLE	Disable comma
BARGRAPH	Enable or change the bargraph
PV (1 or 2)	Set the bargraph to display the PV percentage of full scale
OFF	Turn the bargraph feature off
TOP	Select what to display on the top display
PV (1 or 2)	Display the process variable

Display Functions & Messages	
Parameter	Action/Setting Description
PV+UNIT (1 or 2)	Display the process variable and units alternating
PV+TAG (1 or 2)	Display the process variable and tag alternating
TAG+UNIT	Display tag and units alternating
PV+U+TAG (1 or 2)	Display the process variable, unit, and tag alternating
PV 1+PV 2	Display both process variables (dual-scale only; see PV 2 under advanced features menu)
TAG	Display the tag
STPWATCH	Display the stopwatch
TIMR OC 1	Display open collector 1 timer
TIMR OC 2	Display open collector 2 timer
TIMER R 1	Display relay 1 timer
TIMER R 2	Display relay 2 timer
MIN	Display minimum value
MAX	Display maximum value
MIN MAX	Display alternating min and max
OFF	Turn top display off
UNITS	Display the units
BOTTOM	Select what to display on the bottom display
UNITS	Display the units
PV (1 or 2)	Display the process variable
PV+UNIT (1 or 2)	Display the process variable and unit alternating
PV+TAG (1 or 2)	Display the process variable and tag alternating
TAG+UNIT	Display the tag and unit alternating
PV+U+TAG (1 or 2)	Display the process variable, unit, and tag alternating
PV 1+PV 2	Display both process variables (dual-scale only; see PV 2 under advanced features menu)
TAG	Display the tag
STPWATCH	Display the stopwatch
TIMR OC 1	Display open collector 1 timer
TIMR OC 2	Display open collector 2 timer
TIMER R 1	Display relay 1 timer
TIMER R 2	Display relay 2 timer
OFF	Turn bottom display off
PV PCT (1 or 2)	Display the process variable percentage of full scale
mA IN	Display the current mA input value
mA OUT	Display the current mA output value

Main Menu

The main menu consists of all the meter's programmable functions: *Input*, *Output*, *Advanced*, and *Display*.

- Press **Menu** button to enter *Programming Mode* then press the **Right-Arrow** button to move forward through the menu and the **Up-Arrow** button to move back.
- Press **Menu** at any time to go back one level or press & hold to exit and return to *Run Mode*. Changes made to settings prior to pressing **Enter** are not saved.
- Changes to the settings are saved to memory only after pressing **Enter/F3** to confirm the setting or pressing **Enter/F3** at the **SAVE?** screen when available.

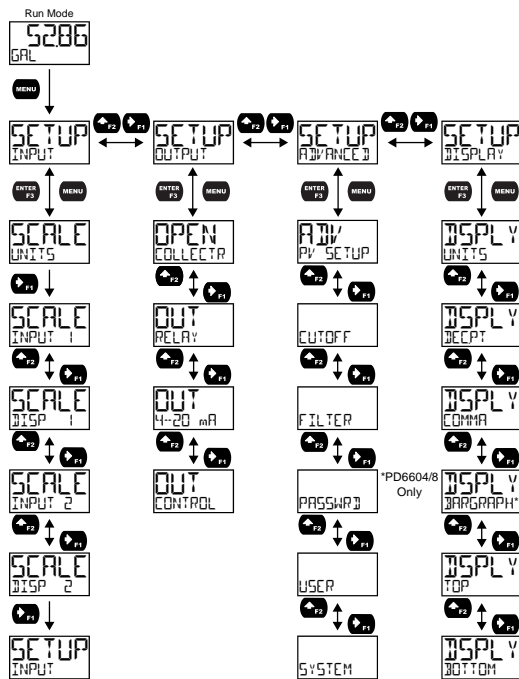

Setting Numeric Values

The numeric values are set using the **Right** and **Up-Arrow** buttons.

1. Press **Right-Arrow** to select next digit and **Up-Arrow** to increment digit value. The selected digit will flash.
2. Press and hold **Up-Arrow** to auto-increment the display value. If you have made a mistake or would like to enter a new value, select the left-most digit, and press and hold the **Right-Arrow** button until all digits reset to zero.
3. Press the **Enter** button at any time to accept a setting or **Menu** button to exit without saving changes.

Note: the underscore in the graphic below is provided to show which digit would be flashing.

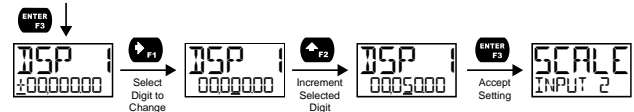

Scaling the 4-20 mA Input (INPUT)

It is **very important** to read the following information before proceeding to program the meter:

- The meter is factory calibrated prior to shipment to display 0.00 to 100.00 gal, which corresponds to the 4-20 mA input. The calibration equipment is traceable to NIST standards.
- A calibrated signal source is not needed to scale the meter.

Enter the *Input* menu to scale the meter to display the 4-20 mA input. The input can accept any signal from 4 to 20 mA.

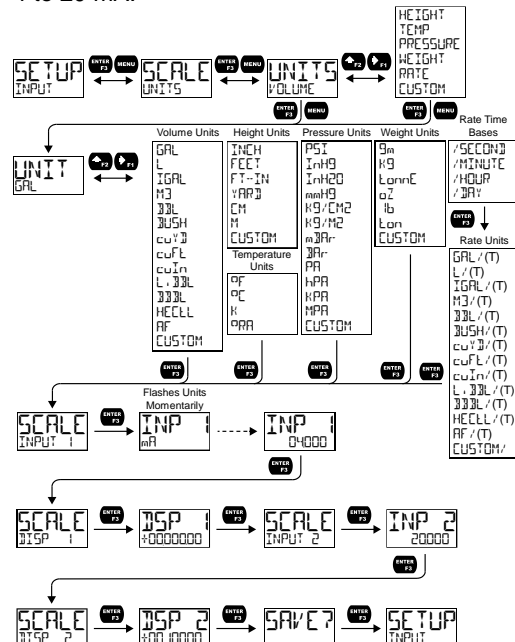

Available Unit Classes and Units

The meter has six available preprogrammed unit classes: *volume*, *height*, *temperature*, *pressure*, *weight*, and *rate*. Each unit class has the following available units to choose from:

Volume Units (VOLUME)	
GAL	Gallons
L	Liters
IGAL	Imperial Gallons
M3	Cubic Meters
BDL	Barrels
BUSH	Bushels
CUYD	Cubic Yards
CUFE	Cubic Feet
CUIN	Cubic Inches
L.BDL	Liquid barrels
BBBL	Beer barrels
HECLL	Hectoliter
AF	Acre-Foot
CUSTOM	Custom Unit

Height Units (HEIGHT)	
INCH	Inches
FEET	Feet
FT-IN	Feet & Inches
YARD	Yards
CM	Centimeters
M	Meters
CUSTOM	Custom unit

Temperature Units (TEMP)	
°F	Degrees Fahrenheit
°C	Degrees Celsius
K	Kelvin
°RA	Degrees Rankine

Pressure Units (PRESSURE)	
PSI	Pounds per square inch
InHG	Inches of mercury
InH2O	Inches of water
mmHG	Millimeters of mercury
KG/CM2	Kilograms per square centimeter
KG/M2	Kilograms per square meter
mBAR	Millibar
BAR	Bar
PA	Pascal
hPA	Hectopascal
kPA	Kilopascal
MPA	Megapascal
CUSTOM	Custom unit

Weight Units (WEIGHT)	
Gm	Grams
KG	Kilograms
TonNE	Tonnes (metric)
oz	Ounces
lb	Pounds
Ton	Tons
CUSTOM	Custom unit

Rate Time Bases (TIME)	
/SECOND	Units per second
/MINUTE	Units per minute
/HOUR	Units per hour
/DAY	Units per day

Rate Units (RATE)	
GAL / (T)	Gallons per time unit (T)
L / (T)	Liters per time unit (T)
IGAL / (T)	Imperial gallons per time unit (T)
M3 / (T)	Cubic meters per time unit (T)
BDL / (T)	Barrels per time unit (T)
BUSH / (T)	Bushels per time unit (T)
CUYD / (T)	Cubic Yards per time unit (T)
CUFE / (T)	Cubic Feet per time unit (T)
CUIN / (T)	Cubic Inches per time unit (T)
L.BDL / (T)	Liquid barrels per time unit (T)
BBBL / (T)	Beer barrels per time unit (T)
HECLL / (T)	Hectoliter per time unit (T)
AF / (T)	Acre-Foot per time unit (T)
CUSTOM /	Custom unit per time unit (T)

Setting Custom Units (CUSTOM)

When the desired unit class or unit of measure within a class is not available, a custom unit may be programmed. Select the CUSTOM menu (or CUSTOM unit within a unit class) to enter a custom unit name.

Text values are set using the *Right* and *Up* arrow buttons. Press *Right* arrow to select next character and *Up* arrow to increment character value. The selected character will flash. Press and hold the *Up* or *Right* arrow buttons to auto-increment or decrement the character. Press Enter to accept the character.

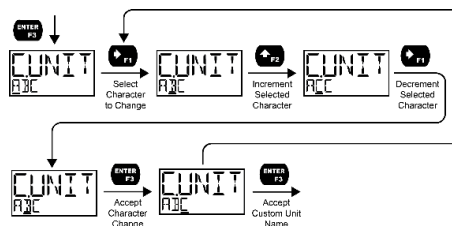

Notes:

- Press and hold the **Right-Arrow** while no character is being edited to erase all characters to the right of the flashing character
- Press and hold **Up** or **Right-Arrow** to auto-increment or decrement a selected character.
- All text values, including tags and alarm messages, are set in a similar fashion.

Setting the Display Features (DISPLAY)

The meter's display functions may be programmed using the *Display* menu. This menu consists of the following submenus: *Units*, *Decimal Point*, *Comma*, *Bargraph*, *Top*, and *Bottom*.

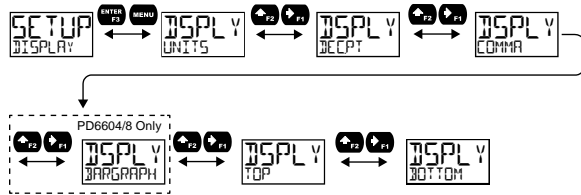

Changing the Engineering Units (UNITS)

It is possible to change the engineering units within the selected unit class without the need to re-scale the meter. When selecting a new unit from within the *DISPLAY* menu (e.g. changing from gallons (GAL) to liters (L)), the meter will automatically convert the display values to display the new unit. Enter the *UNITS* menu, select a new unit of measure from the list of predefined units, and press the **Enter** button. If entering a custom unit (*CUSTOM*), a custom conversion factor will need to be entered.

Changing the Decimal Point (DECPT)

The decimal point may be set with up to seven decimal places or with no decimal point at all.

Pressing the **Right-Arrow** moves the decimal point one place to the right until no decimal point is displayed, and then it moves to the left most position. Pressing the **Up-Arrow** moves the decimal point one place to the left.

If the dual-scale level feature is selected, the decimal point selections for PV1 & PV2 are enabled.

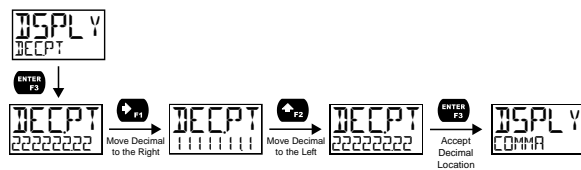

Enabling or Disabling Commas on the Bottom Display (COMMA)

The bottom display is set to show a comma separating the thousands and millions place by default if a numeric value is being displayed. This feature can be disabled or enabled using the *Comma* menu.

Display Capabilities Optimization (TOP and BOTTOM)

Display Configuration Examples

The meter's dual-line display can be setup in multiple ways to provide an extremely informative view of the process variable being monitored. The following graphics show typical configurations:

Top Display: Process Variable
Bottom Display: Engineering Units or Tag



Top Display: Process Variable
Bottom Display: Toggling Between Units and Tag

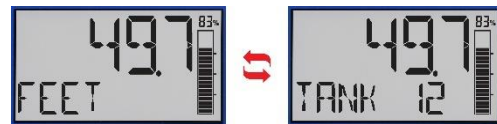

Dual-Scale Mode:
Top Display: Toggling Between Process Variable and Units
Bottom Display: Toggling Between Process Variable (in different scale) and Different Units

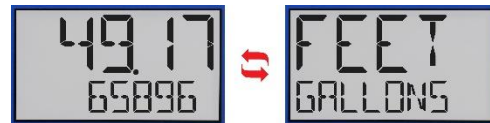

Note: To display units as GALLONS, select custom units and enter the desired text.

Top Display: Toggling Between Process Variable and Units
Bottom Display: Percent

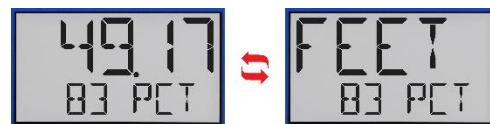

Top Display: Maximum Value
Bottom Display: Process Value



Configuring the Display (TOP and BOTTOM)

The display is configured using the TOP and BOTTOM menus in the DISPLAY menu. Additional menus are available if the meter is in dual-scale mode to allow the second PV to be displayed on either the top or bottom display.

The top display (TOP) can display:

- Process Value (PV)
- Process Value 2 (dual-scale only; see PV 2 under advanced features menu)
- Alternating PV and Units
- Alternating PV and Tag
- Alternating PV, Units, and Tag
- Tag
- Stopwatch
- Open Collector 1 or 2 Timer
- Relay 1 or 2 Timer
- Minimum Value, Maximum Value, or Both
- Off (Blank)
- Units

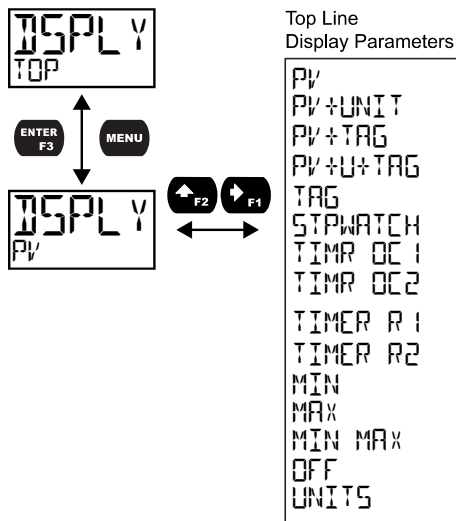

The bottom display (BOTTOM) can display:

- Units
- Process Value (PV)
- Process Value 2 (dual-scale only; see PV 2 under *Advanced Features* Menu)
- Alternating PV and Units
- Alternating PV and Tag
- Alternating Tag and Units
- Alternating PV, Units, and Tag
- Tag
- Stopwatch
- Open Collector 1 or 2 Timer
- Relay 1 or 2 Timer
- Off (Blank)
- PV's Percentage of Full Scale
- The mA Input
- The mA Output

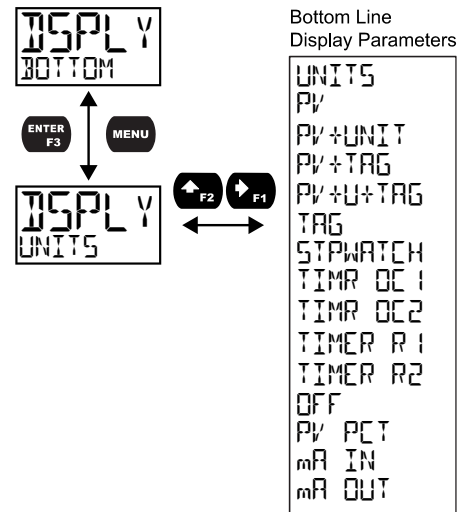

Programming the Bargraph (BARGRAPH)

The DPM-400 comes equipped with a bargraph display for applications where a visual representation of the process variable's percentage of full scale is desirable. This feature can be enabled or disabled using the *Bargraph* menu (BARGRAPH). The value displayed on the bargraph can be the percentage of full scale (PV PCT) or the percentage of a user-programmable range (PV). If the meter is in dual-scale mode, the bargraph can be assigned to display either PV1 or PV2 using this menu.



Programming the Outputs (OUTPUT)

Depending on the model purchased, the meter may be available with two open collector outputs, two solid state relays, and one 4-20 mA output. The *Output* menu will only show options for the available outputs. See *Ordering Information* on page 8 for details.

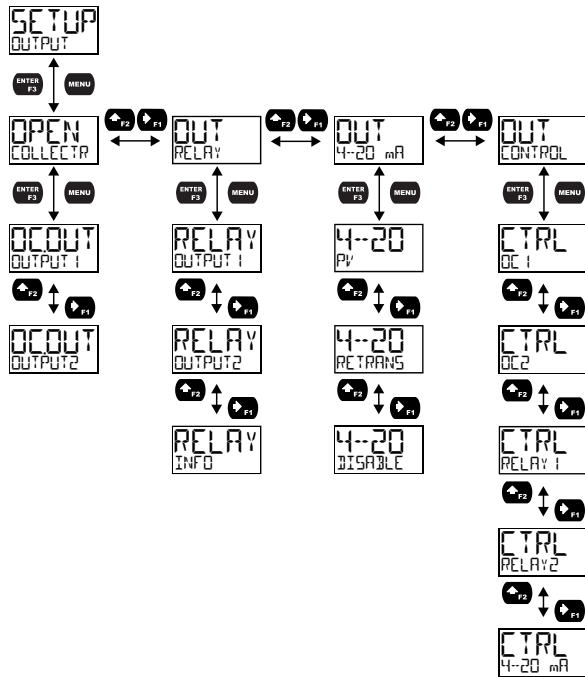

Open Collector Outputs (OPEN COLLECTR)

The meter is equipped with two NPN open collector outputs as a standard feature that may be set up for pulse outputs, alarms, timed pulses, or disabled.

Pulse outputs can be set to transmit the PV value (PV1 or PV2 if meter is in dual-scale mode). Output 2 may be used to generate a quadrature output based on the other open collector output. An output test mode is also selectable to generate pulses at a constant programmable frequency.

Alarms are available based on the PV value or the digital input. The alarm status will show on the display even if the output is not wired.

A timer output (TIMER) turns the open collector on and off at the specified time intervals. The timer can be set as single-shot or continuous timer.

The stopwatch output (STPWATCH) allows the open collector to be manually activated by starting the stopwatch. The stopwatch count can be displayed on the top or bottom display.

The output may be disabled by selecting **DISABLE**.

The Open Collector Outputs are programmed in the following manner:

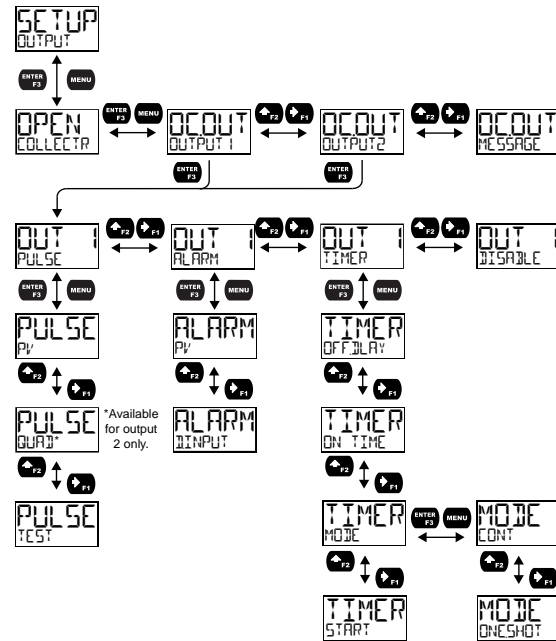

Pulse Output (PULSE)

The pulse outputs may be programmed to generate a scaled frequency based on the PV and a programmable factor. The factor determines the number of pulses per second generated per unit of measure. For example, if the meter display shows 100 gallons and the factor is set to 2, the number of pulses generated per second would be 200. The maximum frequency is 1,000 Hz.

Setting output 2 to quadrature will duplicate the other open collector output, but lag by 90 degrees out of phase. The other output should be programmed as desired for the quadrature output function and must be a pulse (PULSE) output selection. The quadrature maximum frequency for both outputs is 500 Hz.

The TEST option will output a fixed number of pulses per second based on the FREQ value entered.

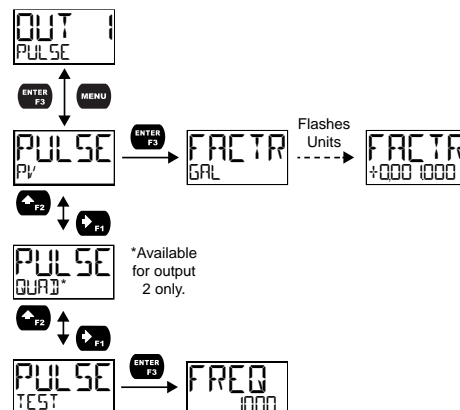

Alarm (ALARM)

Alarm outputs may be assigned to the PV or the digital input. When assigned to the PV, the alarm may be set as either a high alarm or a low alarm. Alarm actions (AUTO, AUTOMAN, LATCH, L-CLEAR) determine how and when the alarm should be reset. They operate as follows:

- **Automatic (AUTO):** Alarm will reset automatically once the alarm condition has cleared.
- **Automatic/Manual (AUTOMAN):** Alarm will reset automatically once the alarm condition has cleared but can also be reset using the **Enter** (ACK) button (or whichever function key is set to acknowledge) at any time.
- **Latching (LATCH):** Alarm must be reset manually and can be done so at any time. Press the **Enter** (ACK) button at any time to clear the alarm.
- **Latching with Reset after Clear (L-CLEAR):** Alarm must be reset manually and can only be done so after the alarm condition has cleared. Press the **Enter** (ACK) button after the alarm condition has cleared to reset the alarm.

If the alarm is set to PV, a set and reset point must be programmed. The set point is the display value at which the alarm will turn on and the reset point is the display value at which the alarm will turn off. If the set point is lower than the reset point, the alarm will be a low alarm; if the set point is higher than the reset point, the alarm will be a high alarm. The digital input alarm will trigger whenever the digital input is triggered.

For both the PV and digital input alarms, a delay before the alarm is turned on or off may be set, as well as a fail-safe feature which reverses the on/off operation of the open collectors.

Alarm states will be displayed on the meter even if no open collector output is physically connected. These may include a red LED backlight, flashing PV value (PV alarm only), and a programmable alarm message. In addition, for meters without a bargraph an alarm indicator (!) will also display.

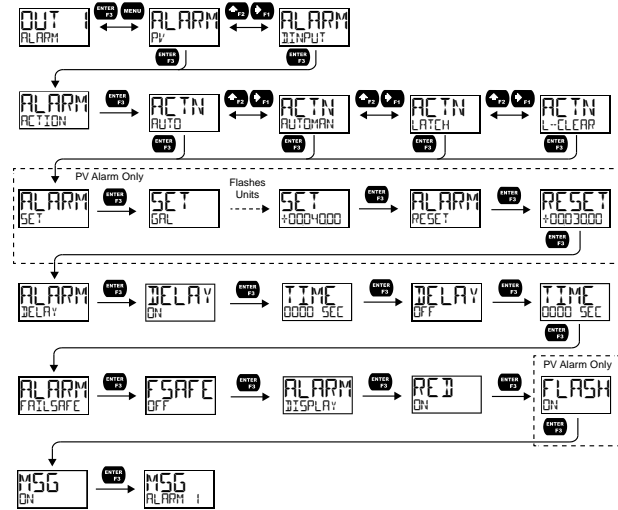

Flashing Red Alarm (RED)

The last two lines in the preceding menu flow chart show how to program the display to turn red, flash, and display a message when an alarm occurs.

Alarm 1 is High Alarm:



Alarm 2 is Low Alarm:



Timer (TIMER)

The timer output may be set to generate the timed pulse only once (ONESHOT) or continuously (CONT).

The timer output produces a constant width pulse at a constant frequency, if set as continuous timer.

Program the *Off Delay* (OFFDELAY) from 1 second to 99 hours 59 minutes and 59 seconds. This is the time it takes from selecting START to turning on the output and for how long the output is off in continuous mode.

Program the *On Time* (ON TIME) for the active low pulse from 1 second to 99 hours 59 minutes and 59 seconds (pulse width). This is the period of time for which the output will remain on.

Select *Start* (START) to begin outputting the constant timed pulse.

Select *Stop* (STOP) to end outputting the constant timed pulse.

Function keys or the digital input may be assigned to start and stop timer functions (see the USER menu in the *Advanced Menu*).

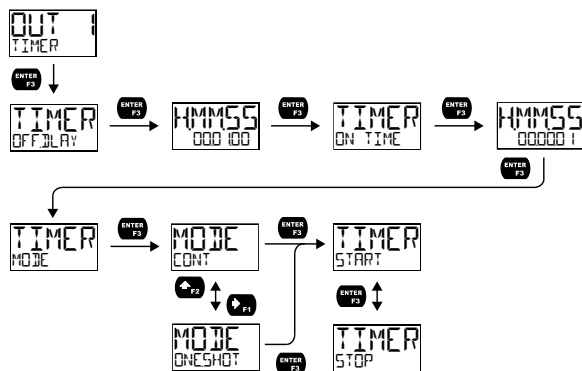

Stopwatch (STOPWATCH)

The stopwatch function may be used to manually run and control a process for a specific time interval up to 99 hrs., 59 min, and 59 seconds. The stopwatch function may be assigned to any open collector. There are three settings needed to use the function effectively.

1. Assign stopwatch to either top or bottom display line
2. Assign the open collector to control the process (on/off)
3. Assign a function key or digital input to start/stop the stopwatch

Application Example

To maintain consistency of a product, it is necessary to take and test samples at different times throughout the day. The stopwatch function is used to open and close a solenoid valve to know the exact amount of time needed to complete the desired sample. Once this is determined, the timer function can be used to automatically take a sample (batch) based on the time determined using the stopwatch function.

Setup: Assign the following to *Stopwatch Function*

- Bottom display line
(see pages 24 & 26 for details how to change the display)
- Relay 1
(see pages 27 & 30 how to change Open Collector and or Solid State Relay functionality)
- F3: Start/Stop
(see pages 36 & 37 for details on how to change the function keys)

Procedure

- Press F3 to start the stopwatch; relay 1 turns on and the process starts running.
- Press F3 to stop the stopwatch; relay 1 turns off and the process stops.
- The bottom display indicates the time it took to complete the sample.

Solid State Relay Outputs (RELAY)

The meter can be optionally equipped with two solid state relays that may be set up for alarms, timer, stopwatch, or pump control. Alternatively, they may be disabled.

Alarms are available based on the PV value or the digital input. The alarm status will show on the display even if the output is not wired.

Pump control allows the relay to turn on and off a pump at specified on and off points. This can be done using only one of the relays to control one pump (ON-OFF) or using both relays in tandem to alternate between two pumps (ALTERN).

A timer output (TIMER) turns the relay on and off at the specified time intervals. The timer can be set as single-shot or continuous timer.

The stopwatch output (STOPWATCH) allows the relay to be manually activated by starting the stopwatch. The stopwatch count can be displayed on the top or bottom display.

The output may be disabled by selecting DISABLE.

CAUTION

- During setup, the relays do not follow the input and they will remain in the state found prior to entering the *Relay* menu.

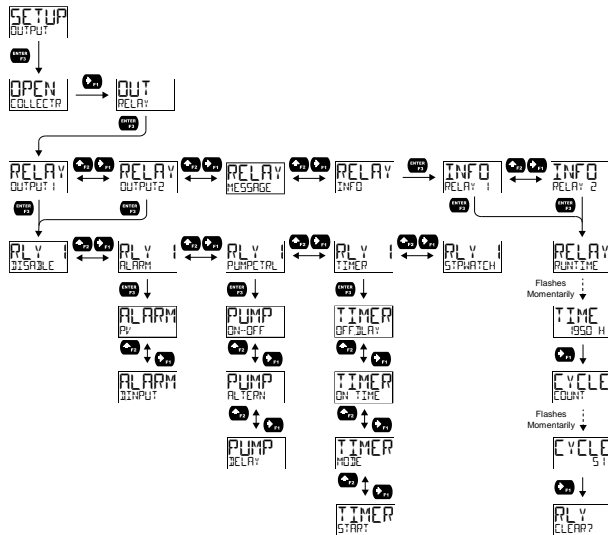

Alarm (ALARM)

Alarm outputs may be assigned to the PV or the digital input. When assigned to the PV, the alarm may be set as either a high alarm or a low alarm. Alarm actions (AUTO, AUTOMAN, LATCH, L-CLEAR) determine how and when the alarm should be reset. They operate as follows:

- **Automatic (AUTO):** Alarm will reset automatically once the alarm condition has cleared.
- **Automatic/Manual (AUTOMAN):** Alarm will reset automatically once the alarm condition has cleared but can also be reset using the *Enter* (ACK) button (or whichever function key is set to acknowledge) at any time.
- **Latching (LATCH):** Alarm must be reset manually and can be done so at any time. Press the *Enter* (ACK) button at any time to clear the alarm.
- **Latching with Reset after Clear (L-CLEAR):** Alarm must be reset manually and can only be done so after the alarm condition has cleared. Press the *Enter* (ACK) button after the alarm condition has cleared to reset the alarm.

If the alarm is set to PV, a set and reset point must be programmed. The set point is the display value at which the alarm will turn on and the reset point is the display value at which the alarm will turn off. If the set point is lower than the reset point, the alarm will be a low alarm; if the set point is higher than the reset point, the alarm will be a high alarm. The digital input alarm will trigger whenever the digital input is triggered.

For both the PV and digital input alarms, a delay before the alarm is turned on or off may be set, as well as a fail-safe feature which reverses the on/off operation of the relays.

Alarm states will be displayed on the meter even if no relay output is physically connected. These may include a red LED backlight, flashing PV value (PV alarm only), and a programmable alarm message.

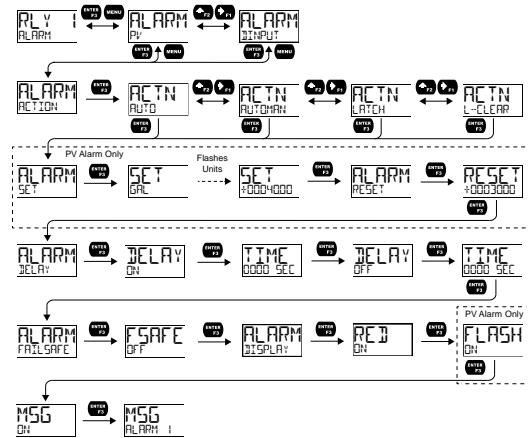

Pump Control (PUMPCTRL)

The pump control output is used in situations where the relays are used to control pumps. There are two options available for controlling pumps: on-off (ON--OFF) and pump alternation (ALTERN).

ON--OFF will turn the relay on at a programmed on point and off at a programmed off point. Setting the on point higher than the off point will make the output activate on a high PV value; setting the on point lower than the off point will make the output activate on a low PV value. The relay will reset automatically.

For pump control applications where two similar pumps are used to control the level of a tank or a well, it may be desirable to have the pumps operate alternately. This prevents excessive wear and overheating of one pump over the lack of use of the other pump. Pump alternation uses both relays in tandem to alternate between two similar pumps. The ALTERN menu is only available under Output 1 and will automatically set Output 2 to pump alternation as well. Use the pump *Alternation Time* setting (ALTIME) to control the alternation based on runtime in addition to level cycles.

On/Off Pump Control (ON--OFF)

When programming a single pump to turn on and off, the on and off points must be programmed. The relay will activate at the on point and deactivate at the off point. On and off delays may be programmed to delay the activation or deactivation of the relay by a certain number of seconds after reaching either the on point or off point.

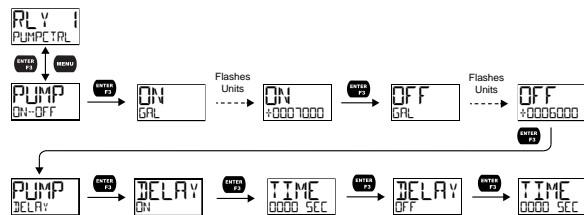

Pump Alternation (ALTERN)

Pump alternation sets the two relays to alternate every time the first on point (ON 1) is reached. The active relay will turn off once the first off point (OFF 1) is reached. If the PV reaches the second on point (ON 2), the other relay will also turn on. The second relay will turn off once the second off point (OFF 2) is reached and the first relay will remain active until the first off point (OFF 1) is reached.

On and off delays may optionally be programmed for each on and off point to delay the activation or deactivation of the relays by a certain number of seconds after reaching either the on point or off point.

For pumps that typically remain on extensively, the alternation time (ALTIME) parameter sets a period of relay on-time after which the relays should alternate. For example, if the alternation time is set to one hour, pump 1 will turn off after one hour of runtime regardless of the level reading, at which point pump 2 becomes the active pump. Pump 2 will run until one hour has passed, or the tank has reached a desirable level; whichever happens first. By using the proper on/off points, the alternation can be set up so that the first pump on is the first pump off. This is desirable when the two pumps are of similar rating.

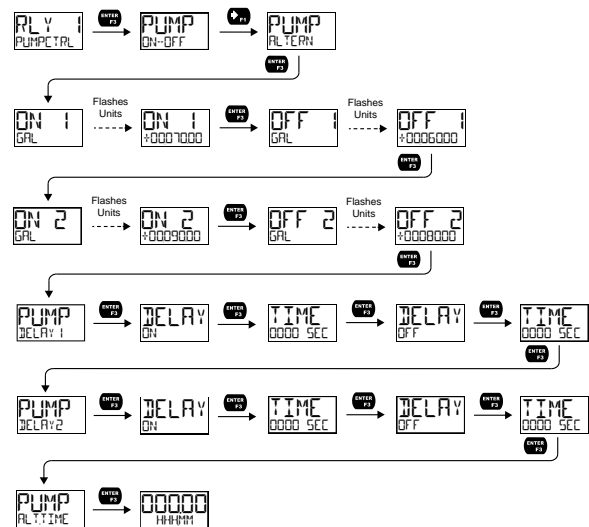

Pump Alternation Example

The following is an example application where the relays are programmed for pump alternation.

On & Off Point Programming			
Relay	On Point	Off Point	Function
1	7000	1000	Controls backup pump
2	6000	1000	Controls main pump

The following graphics provide a visual representation of a typical pump alternation application:

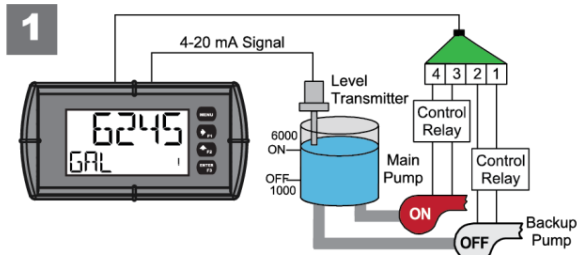

Relay #2 turns the main pump on at 6000 gallons and turns it off at 1000 gallons.

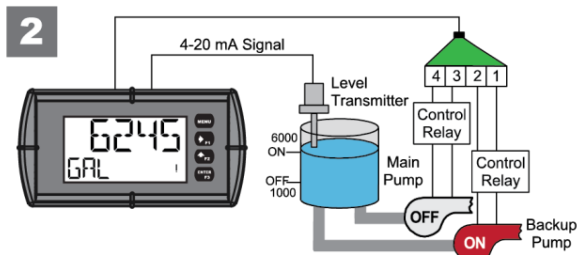

With the Pump Alternation feature activated, the next time the level reaches 6000 gallons, relay #1 transfers and starts the backup pump.

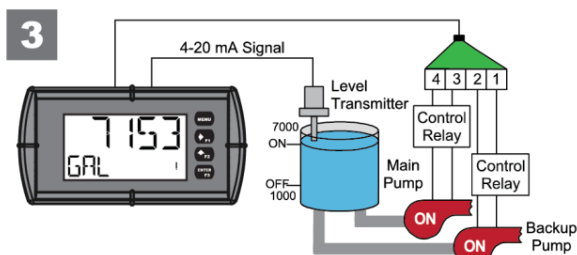

If the backup pump is not able to keep up, and the level reaches 7000 gallons, relay #2 transfers and starts the main pump as well.

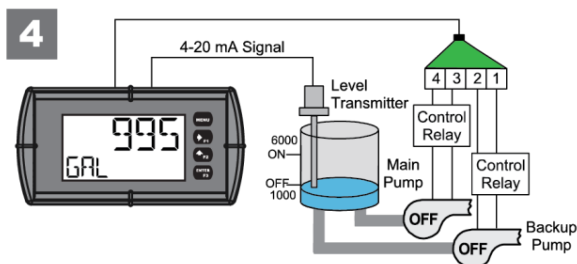

Once the level has dropped below the reset points, both relays will turn off.

Note: Open Collectors can be used for high and low alarm indication.

Timer (TIMER)

The timer output may be set to generate the timed pulse only once (ONESHOT) or continuously (CONT). The timer output produces a constant width pulse at a constant frequency, if set as continuous timer.

Program the *Off Delay* (OFF DELAY) from 1 second to 99 hours 59 minutes and 59 seconds. This is the time it takes from selecting START to turning on the output and for how long the output is off in continuous mode.

Program the *On Time* (ON TIME) for the active low pulse from 1 second to 99 hours 59 minutes and 59 seconds (pulse width). This is the period of time for which the output will remain on.

Select *Start* (START) to begin outputting the constant timed pulse. Select *Stop* (STOP) to end outputting the constant timed pulse. Function keys or the digital input may be assigned to start and stop timer functions (see the USER menu in *Advanced*).

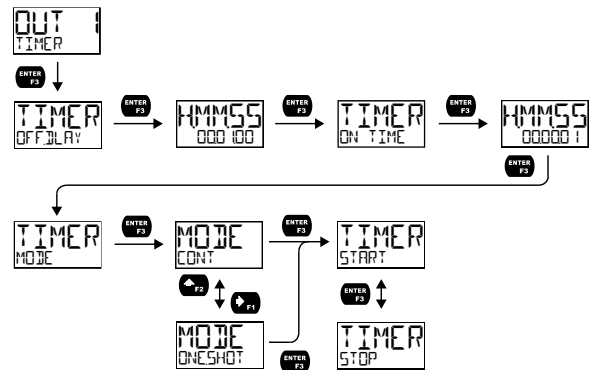

Stopwatch (STPWATCH)

The stopwatch function may be used to manually run and control a process for a specific time interval up to 99 hrs., 59 min, and 59 seconds. The stopwatch function may be assigned to any relay. There are three settings needed to use the function effectively.

1. Assign stopwatch to either top or bottom display line
2. Assign the relay to control the process (on/off)
3. Assign a function key or digital input to start/stop the stopwatch

Application Example

To maintain consistency of a product, it is necessary to take and test samples at different times throughout the day. The stopwatch function is used to open and close a solenoid valve to know the exact amount of time needed to complete the desired sample. Once this is determined, the timer function can be used to automatically take a sample (batch) based on the time determined using the stopwatch function.

Setup: Assign the following to *Stopwatch Function*

- Bottom display line (see pages 24 & 26 for details how to change the display)
- Relay 1 (see pages 27 & 30 how to change Open Collector and or Solid State Relay functionality)
- F3: Start/Stop (see pages 36 & 37 for details on how to change the function keys)

Procedure

- Press F3 to start the stopwatch; relay 1 turns on and the process starts running.
- Press F3 to stop the stopwatch; relay 1 turns off and the process stops.
- The bottom display indicates the time it took to complete the sample.

Runtime & Cycle Count (INFO)

The relay information menu shows runtime and cycle count for each relay. These values may be cleared at any time by selecting the *Clear* option (CLEAR?).

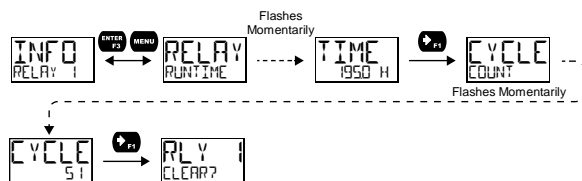

Isolated 4-20 mA Output (4-20 mA)

The 4-20 mA menu is used to scale the isolated 4-20 mA output based on display values. This menu is not present on models without a 4-20 mA output option.

The 4-20 mA analog output can be scaled to provide a 4-20 mA signal for any PV display range or to simply retransmit the 4-20 mA input. The output may be disabled (DISABLE), and will only output the minimum signal.

Overrange and underrange values determine what mA signal the meter will output if the mA input is underrange (<3.5 mA) or overrange (>20.5 mA). This value may be set to 1 mA, 3.5 mA, 3.8 mA, 20.5 mA, 20.8 mA, 23 mA, or disabled.

No equipment is needed to scale the analog output; simply program two display values and corresponding mA output signals.

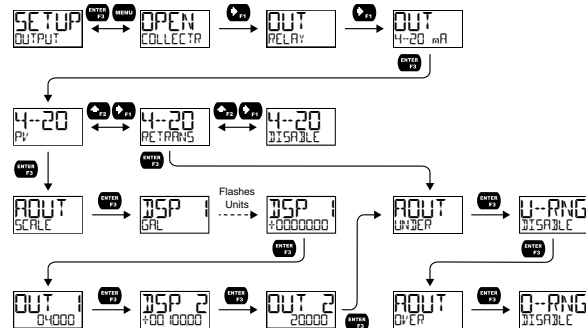

Process Variable (PV)

To scale the analog output, enter display value 1 and a corresponding analog output value for this display, and enter display value 2 and a corresponding analog output value for this display value. This will provide a scaled linear analog output.

Retransmit (RETRANS)

This option will retransmit the 4-20 mA analog input without the need to scale the output.

Output Manual Control (CONTROL)

The *Control* menu is used to control the open collector outputs, 4-20 mA analog output, and the relays manually, ignoring the input. Each open collector, relay, and analog output can be programmed independently for manual control. Selecting automatic control sets all relays and analog output for automatic operation.

After selecting manual control for a specific output, you can set the output value. To change the output value, return to the Control menu, select the output to control, select manual control, and enter a new value.

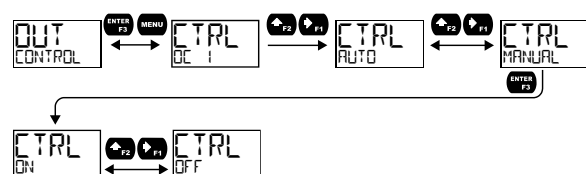

Advanced Features Menu (ADVANCE)

To simplify the setup process, functions not needed for most applications are located in the *Advanced Features* menu. The options under advanced features include *advanced PV setup, cutoff, filter, password, function key programming, and system settings.*

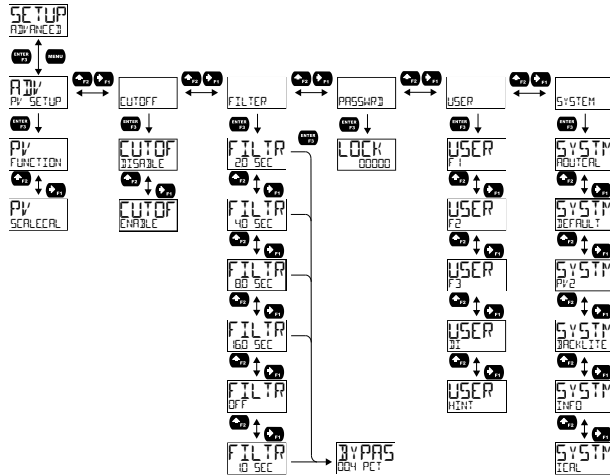

Advanced Process Variable Setup (ADV PV SETUP)

The Advanced PV Setup menu contains options to apply input signal conditioning functions to the input and to scale/calibrate the input signal.

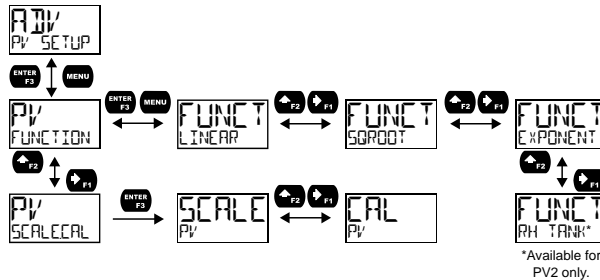

Input Signal Conditioning Functions (FUNCTION)

The *Function* menu is used to select the input signal conditioner applied to the input: linear, square root, programmable exponent, or round horizontal tank volume calculation. Multi-point linearization is part of the linear function selection.

Meters are set up at the factory for linear function with 2-point linearization. The linear function provides a display that is linear with respect to the input signal.

Advanced Scaling and Calibration (SCALECAL)

This menu offers options to scale or calibrate the meter.

Scaling the Input (SCALE)

The scale menu in the *Advanced* menu is the same as the scale menu in the *Input* menu. See *Scaling the 4-20 mA Input (INPUT)* on page 23 for details about scaling the meter.

Calibrating the Input (CAL)

To scale the meter without a signal source, refer to *Scaling the 4-20 mA Input (INPUT)*, page 23.

The meter can be calibrated to display the process in engineering units by applying the appropriate input signal and following the calibration procedure. The *CAL* menu can be used either with a calibrated current source or with a live signal coming from a 4-20 mA transmitter connected to the process being measured.

During calibration, the mA input value will be displayed as *INP 1* and *INP 2*. Adjust the input source until the desired mA value is shown.

The use of a calibrated signal source is required.

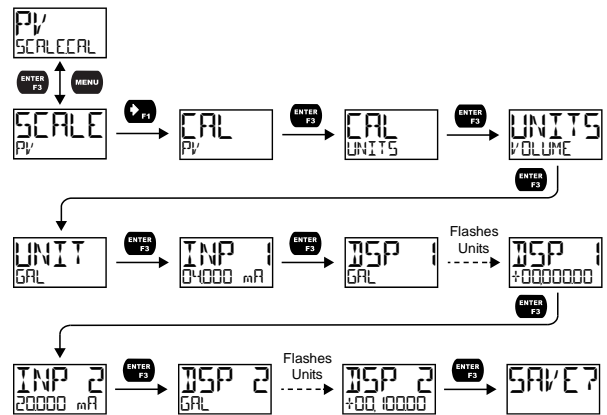

Follow these steps to calibrate the input:

1. After accessing the **SCALECAL** menu, press the **Right-Arrow** button to scroll to the **Calibration** menu (**CAL PV**) and press **Enter**.
2. Select the appropriate units for the desired process variable, then press **Enter**. For information on units, see
3. *Available Unit Classes and Units* on page 24.
4. The meter displays **INP 1**. Apply a known signal and press **Enter**. The display will flash while accepting the signal.
5. After the signal is accepted, the meter displays **ISP 1**. Enter a corresponding display value for the input signal, and press **Enter** to accept.
6. The meter displays **INP 2**. Apply a known signal and press **Enter**. The display will flash while accepting the signal.
7. After the signal is accepted, the meter displays **ISP 2**. Enter a corresponding display value for the input signal and press **Enter** to accept.
8. After completing calibration, the **SAVE?** display will need to be acknowledged using the **Enter** key before calibration will take effect.

Note: The **SAVE?** prompt is not displayed if no changes have been made to the scaling.

Low-Flow Cutoff (CUTOFF)

The low-flow cutoff feature allows the meter to be programmed so that the often-unsteady output from a differential pressure transmitter at low flow rates always displays zero on the meter. The cutoff value may be programmed from 0.1 to 99999. The meter will display zero below the cutoff value. The cutoff can be disabled to display negative values.

Noise Filter (FILTER)

The noise filter is available for unusually noisy signals that cause an unstable process variable display. The noise filter averages the input signal over a certain period of time. The filter level determines the length of time over which the signal is averaged. The filter level can be set between 1 and 16 seconds or turned off. The higher the filter level, the longer the averaging time and so the longer it takes the display to settle to its final value. Setting the filter level to off disables the filter function.

Noise Filter Bypass (BYPASS)

The noise filter bypass changes the behavior of the meter so that small variations in the signal are filtered out but large abrupt changes in the input signal are displayed immediately. The bypass value determines the minimum amount of signal change to be displayed immediately. All signal changes smaller than the bypass value are filtered or averaged by the meter. The noise filter bypass may be set between 0.1 and 99.9% of full scale.

Enabling Password Protection (PASSWORD)

The *Password* menu is used for programming security to prevent unauthorized changes to the programmed parameter settings.

To set a password, enter the *Password* menu and program a five-digit password. For instructions on how to program numeric values see *Setting Numeric Values* on page 23.

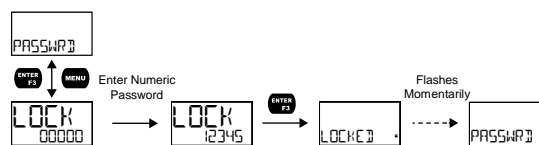

Making Changes to a Password Protected Meter

If the meter is password protected, the meter will display the message **LOCKED** when the *Menu* button is pressed. Press the *Enter* button while the message is being displayed and enter the correct password to gain access to the menu. After exiting *Programming Mode*, the meter returns to its password protected condition.

Disabling Password Protection

To disable password protection, access the *Password* menu and clear the entered password either by pressing and holding the *Right Arrow* button until all digits reset to zero or manually changing all the digits to zero. When the **Enter** button is pressed, the meter will display **UNLOCKED** and will no longer require a password to access *Programming Mode*.

Note: If the meter is password protected and the password has been forgotten, the password may be overridden using the master password: **50865**

Programmable Function Keys User Menu (USER)

The *User* menu allows the user to assign the front panel function keys F1, F2, and F3, and the digital input (located on the input signal connector) to access some of the menus or to activate certain functions immediately (e.g. reset max & min, hold relay states, etc.). This allows the meter to be greatly customized for use in specialized applications.

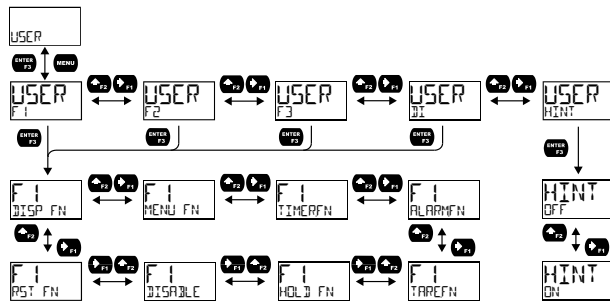

Tare (TARE)

The tare function zero's out the display. In the case of scale weight, tare is used to eliminate container weight and provide net weight readings. There are two tare functions; Tare and Reset Tare. When the tare function is used, the display reading is offset by the displayed amount to make the displayed value zero. Reset tare removes the display offset of the net value, and the gross and net values become the same until a new capture tare is entered.

Program a function key or the digital input for the tare and reset tare.

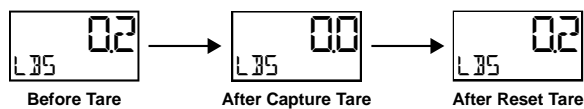

Function Keys & Digital Input Available Settings

Refer to the following table for descriptions of each available function key or digital input setting.

Display	Description
DISP FN	Set the function key or digital input to display a value
DISPLAY	Cycle max, min, and PV(s)
DISP PV	Display the PV
PCT PV	Display the PV's percentage of max (20 mA)
UNITS	Display the PV's units
TAG	Display the PV's tag
DISPMIN	Display the PV's minimum
DISPMAX	Display the PV's maximum
MIN MAX	Display the PV's minimum and maximum value
mA IN	Display the mA input value
mAOUT	Display the mA output value
MENU FN	Set the function key or digital input to access a menu
RLY INFO	Go to relay information menu (INFO)
MANCTRL	Go to output control menu (CONTROL)
TMR OC 1	Open collector 1 timer
TMR OC 2	Open collector 2 timer
TIMER R 1	Relay 1 timer
TIMER R 2	Relay 2 timer
TIMERFN	Set the function key or digital input to start or stop a timer
STARTALL	Start all timers
STOPALL	Stop all timers
SSTPALL	Start or stop all timers
OC 1	Start/stop open collector 1 timer
OC 2	Start/stop open collector 2 timer
RLY 1	Start/stop relay 1 timer
RLY 2	Start/stop relay 2 timer
START	Start the selected timer output
STOP	Stop the selected timer output
STR--STP	Start or stop the selected timer output

Display	Description
ALARMFN	Set the function key or digital input to acknowledge an alarm
ACK	Acknowledge all active alarms
SETPOINT	Set all output set point
SETPTOC 1	Set open collector 1 set point
SETPTOC 2	Set open collector 2 set point
SETPTR 1	Set relay 1 set point
SETPTR 2	Set relay 2 set point
SWATCHFN	Set the function key or digital input to activate stopwatch
START	Start the stopwatch
STOP	Pause/Stop the stopwatch
STR--STP	Start or stop the stopwatch
TAREFN	Set the function key or digital input to tare the display value
TARE	Tare the display value
RST TARE	Reset the display value
HOLD FN	Set the function key or digital input to hold an output
HOLDOUT	Hold all outputs
HL UNHLD	Hold or un-hold all outputs
OC 1+2	Hold/un-hold open collector outputs
RLY 1+2	Hold/un-hold relay outputs
mAOUT	Hold/un-hold 4-20 mA output
HOLD	Hold selected output
HL UNHLD	Hold or un-hold selected output
DISABLE	Disable the function key or digital input
RST FN	Set the function key or digital input to reset a value
RESET	Reset min, max, or max/min PV value
R MINMAX	Reset max and min PV value

Enabling the Function Key Hint Feature (HINT)

Enabling the function key hint feature will cause a hint message to be displayed when pressing the F1, F2, or F3 function keys. This text gives a brief description of what the button is programmed to do. Pressing that function key a second time will execute that action.

The hint feature does not affect the digital input (DI) which is intended for immediate execution.

Changing System Settings (SYSTEM)

The System menu contains the following menus: *Analog Output Calibration, Restore Factory Defaults, Dual-Scale (PV2), Backlight, Information, and Internal Calibration.*

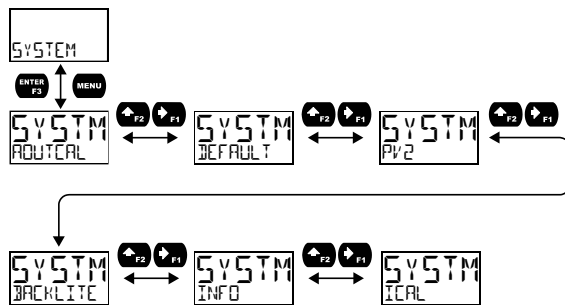

Analog Output Calibration (ADUTCAL)

To perform the analog output calibration, it is recommended to use a milliamp meter with a resolution of at least 0.1 μ A to measure the output current. The values saved internally during this procedure are used for scaling the 4-20 mA output in the *Setup* menu.

4-20 mA Output Calibration Procedure

1. Go to the *Advanced Features* menu and navigate to the **SYSTEM** menu and press Enter. Navigate to **ADUTCAL** and press Enter.
2. The display will show 4 mA. The DPM-400 mA output should now be close to 4 mA. Enter the actual value read by the digital mA meter on the second line of the display and press Enter.
3. The display will show 20 mA. The DPM-400 mA output should now be close to 20 mA. Enter the actual value read by the digital mA meter on the second line of the display and press Enter.
4. The DPM-400 will now calculate the calibration factors and store them.
5. Press Menu to exit.

Enabling the Dual-Scale Feature (PV2)

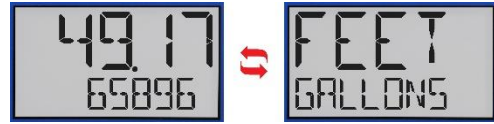

Dual-Scale Mode

Top Display: Toggling Between Process Variable and Units

Bottom Display: Toggling Between Process Variable (in different scale) and Different Units

For some level applications, such as displaying the height and volume of a tank, a second PV can be enabled which can be scaled to display a different value based on the same 4-20 mA input. This is accomplished by enabling the dual-scale feature (PV2).

When the dual-scale feature is enabled, additional menus will be displayed to allow for the programming of the second PV. The input menu will display PV1 and PV2 for scaling and the display menu will allow both PVs to be displayed on either line, for example. See on page 18 for additional information on where additional dual-scale specific menus will appear.

PV2 must be enabled to use the Round Horizontal Tank feature.

Enabling or Disabling the Backlight (BACKLITE)

The backlight may be enabled or disabled using the Backlight menu. The backlight is enabled by default, but the input must be wired appropriately for the backlight to function. See *Display Functions & Messages* on page 19. The voltage drop is the same if the backlight is not wired or if it is disabled in the *System* menu.

Viewing System Information (INFO)

System information, such as software (firmware) number and version, model number, and system tag, may be viewed in the **INFO** menu. Press the *Right Arrow* button to cycle through all available meter information. Press **Menu** to go back to the previous menu.

Calibrating the Internal mA Reference (ICAL)

The meter is factory calibrated prior to shipment to display 0.00 to 100.00, which corresponds to the 4-20 mA input. The calibration equipment is traceable to NIST standards.

The use of calibrated signal sources is necessary to calibrate the internal source of the meter. The meter's internal source is what allows the user to scale the meter without applying a signal.

Check calibration of the meter at least every 12 months.

Note: Allow the meter to warm up for at least 15 minutes before performing the internal source calibration procedure.

The *Internal Calibration* menu is part of the *Advanced* menu. Internal Calibration is performed as follows:

1. Press the **Menu** button to enter *Programming Mode*.
2. Press the **Up-Arrow** button **twice** and press **Enter** to access the **Advanced** menu.
3. Press the **Up-Arrow** button and press **Enter** to access the **System** menu.
4. Press the **Up-Arrow** button and press **Enter** to access the **ICAL** menu.
5. The meter displays *low* input current message (4000 mA). Apply a 4 mA signal and press **Enter**. The display flashes for a moment while the meter is accepting the low input signal.
6. After the display stops flashing, the display moves to the *high* input calibration (20000 mA). Apply the high input signal and press **Enter**. The display will flash again while the meter is accepting the high input signal.

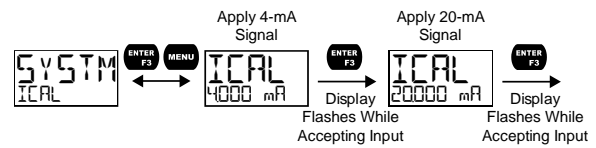





Meter Operation

The meter can accept a 4-20 mA current signal and display it in engineering units from -9999 to 99999 on the top display or from -9,999,999 to 99,999,999 (with commas, if desired) on the bottom display. For example, a 4-20 mA signal could be displayed as -50.00 to 50.00 on the top display.

The dual-line display can be customized to display the process variable and other parameters in a wide variety of ways. Typically, the top display is used for the process variable while the bottom display is used for engineering units, custom tag, or process variable percentage of full scale.

The 4-20 mA input can be scaled to display the process in two different scales; for example: with *PV2* enabled, the top display could indicate level in feet and the bottom display could indicate the volume in gallons.

Front Panel Buttons Operation

Button Symbol	Description
	Press to enter or exit <i>Programming Mode</i> , view settings, or exit max/min readings
	Press to display max/min readings or other parameter/function assigned through the <i>User menu</i>
	Press to reset max/min readings or other parameter/function assigned through the <i>User menu</i>
	Press to acknowledge alarms or other parameters/function assigned through the <i>User menu</i>

Function Keys Operation

During operation, the programmable function keys operate according to the way they have been programmed in the *Advanced Features – User menu*. The table under *Front Panel Buttons Operation* shows the factory default settings for F1, F2, and F3.

A hint message may be enabled to provide a description of what each function key does prior to executing their assigned function. See *Enabling the Function Key Hint Feature (HINT)* on page 38.

Digital Input Operation

A digital input is standard on the meter. This digital input is programmed identically to function keys F1, F2, and F3. The input is triggered with a contact closure between DI+ and DI-, or with an active low signal. During operation, the digital input operates according to the way it has been programmed in the *Advanced Features – User menu*.

Maximum/Minimum Readings

The max & min readings (peak & valley) reached by the process can be displayed either continuously or momentarily.

Display momentarily by pressing the F1 key (default) or assigning to any of the other function keys or to the digital input in the *User menu*.

Display continuously by pressing the **Enter** button while the max/min is being displayed to lock the display. Press **Enter** again to unlock.

Any of the F1-F3 function keys (buttons) and the digital input can be programmed to reset the max & min readings. The meters are set at the factory to display the max reading by pressing the *Right Arrow/F1* button and to use the *Up-Arrow/F2* button to access the *Reset menu*. Press the *Right Arrow* button to cycle through the available parameters to reset.

Top Display: Process Value
Bottom Display: Max & Min

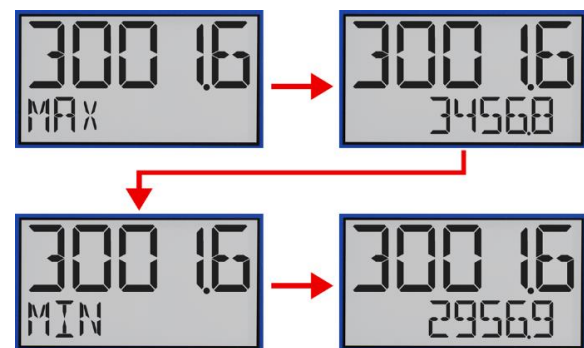

Runtime & Cycle Count (INFO)

The relay information menu shows runtime and cycle count for each relay. These values may be cleared at any time by selecting the *Clear* option (CLEAR?). If the cycle count or runtime values need to be changed on a frequent basis, it would be convenient to set up a front panel button or the digital input to simplify this process.

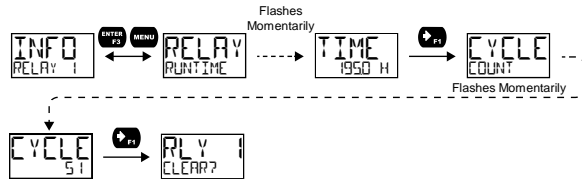

Note: See the menu tree under *Solid State Relay Outputs (RELAY)* on page 30 for complete menu structure on this feature.

Meter displaying the amount of time a relay has been activated



Meter displaying the number of times a relay has cycled



Changing Engineering Units

During operation of the meter, it is possible to change the display units within the selected unit class without the need to re-scale the meter. The **UNITS** menu in the **DISPLAY** menu allows the unit of measure to be changed (e.g. from gallons/second (GAL/S) to liters/second (L/S)) and the meter will automatically convert the display values to the new unit of measure. If entering a custom unit (CUSTOM), a custom conversion factor will need to be entered. See *Changing the Engineering Units (UNITS)* on page 25.

Troubleshooting

This product is a highly sophisticated instrument with an extensive list of features and capabilities. If the front panel buttons are used to program the meter, it can be a difficult task to keep everything straight. That is why we strongly recommend the use of the free [MeterView XL](#) software for all programming activities. A cable is provided to use the MeterView XL software for programming the meter.

If you have programmed the meter with the front panel buttons and it is not working as intended, try re-programming the meter using the MeterView XL software.

Reset Meter to Factory Defaults

When the parameters have been changed in a way that is difficult to determine what's happening, it might be better to start the setup process from the factory defaults. This can be accomplished using MeterView XL software or with the front panel buttons.

To load factory defaults:

1. Press the **Menu** button to enter *Programming Mode*.
2. Press the **Right-Arrow** button **twice** and press **Enter** to access the **Advanced** menu.
3. Press the **Up-Arrow** button and press **Enter** to access the **System** menu.
4. Press the **Right-Arrow** button and press **Enter** to access the **Default** menu.
5. Press **Enter** twice in quick succession. The meter will load default settings and restart.

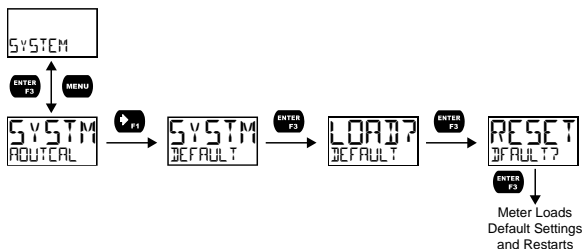

Determining Software Version

To determine the software (firmware) version of a meter:

1. Press the **Menu** button to enter *Programming Mode*.
2. Press the **Up-Arrow** button **twice** and press **Enter** to access the **Advanced** menu.
3. Press the **Up-Arrow** button and press **Enter** to access the **System** menu.
4. Press the **Up-Arrow** button **twice** and press **Enter** to access the **Info** menu.
5. Press the **Right-Arrow** button to cycle through the meter information. When done, press the **Menu** button to return to the previous menu or press & hold **Menu** to exit to Run mode.

Factory Default Settings

The following table shows the factory setting for most of the programmable parameters on the meter.

Parameter	Display	Default Setting
Input Menu		
Unit Class	UNITS	Volume
Unit of Measure	UNIT	Gallons
Input 1	INP 1	4.000 mA
Display 1	DSP 1	0.00
Input 2	INP 2	20.000 mA
Display 2	DSP 2	100.00
Output Menu		
Open Collector Output 1	OUTPUT 1	Disabled
Pulse Factor	FACTOR	1.0
Test Frequency	FREQ	100
Alarm	ALARM	PV
Alarm Action	ACTION	AUTO
Set Point	SET	20.00
Reset Point	RESET	10.00
Alarm On Delay	DELAY ON	0 seconds
Alarm Off Delay	DELAY OFF	0 seconds
Alarm Fail-safe	FAILSAFE	OFF
Red LED	RED	ON
Flash PV	FLASH	ON
Alarm Message	MSG	ON
Message Text	MSG EDIT	ALARM 1
Timer Off Delay	OFF DELAY	1 minute
Timer On Time	ON TIME	1 second
Timer Mode	MODE	Continuous
Open Collector Output 2	OUTPUT 2	Disabled
Set Point	SET	40.00
Reset Point	RESET	30.00
Message Text	MSG EDIT	ALARM 2
Relay Output 1	RELAY 1	Disabled
Alarm	ALARM	PV
Alarm Action	ACTION	AUTO
Set Point	SET	70.00
Reset Point	RESET	60.00
Alarm On Delay	DELAY ON	0 seconds
Alarm Off Delay	DELAY OFF	0 seconds
Alarm Fail-safe	FAILSAFE	OFF
Red LED	RED	ON
Flash PV	FLASH	ON
Alarm Message	MSG	ON
Message Text	MSG EDIT	ALARM 3

Pump Ctrl On	ON	70.00
Pump Ctrl Off	OFF	60.00
Pump Ctrl On Delay	DELAY ON	0 seconds
Pump Ctrl Off Delay	DELAY OFF	0 seconds
Pump Alt On 1	ON 1	70.00
Pump Alt Off 1	OFF 1	60.00
Pump Alt On 2	ON 2	90.00
Pump Alt Off 2	OFF 2	80.00
Pump Alt On Delay 1	DELAY 1 ON	0 seconds
Pump Alt Off Delay 1	DELAY 1 OFF	0 seconds
Pump Alt On Delay 2	DELAY 2 ON	0 seconds
Pump Alt Off Delay 2	DELAY 2 OFF	0 seconds
Timer Off Delay	OFF DELAY	1 minute
Timer On Time	ON TIME	1 second
Timer Mode	MODE	Continuous
Relay Output 2	RELAY 2	Disabled
4-20 mA Output	4-20 mA	PV

Advanced Menu		
Signal Conditioning Function	FUNCTION	Linear (2 pts)
Low Cutoff	CUTOFF	Enabled: 0
Filter	FILTER	2.0 seconds
Filter Bypass	BYPAS	0.4 PCT
Password	PASSWORD	00000 (Unlocked)
Function Key 1	F 1	Display
Function Key 2	F 2	Reset
Function Key 3	F 3	Acknowledge
Digital Input	DI	Acknowledge
Function Key Hint Feature	HINT	Disabled
Dual-Scale	PV 2	Disabled
Backlight	BACKLIGHT	Enabled
Display Menu		
Unit of Measure	UNITS	Gallons
Decimal Point Location	DECP T	2
Comma	COMMA	Enabled
Top Display	TOP	PV
Bottom Display	BOTTOM	Units
Signal Conditioning Function	FUNCTION	Linear (2 pts)
Low Cutoff	CUTOFF	Enabled: 0

Troubleshooting Tips

Certain sequences of events can cause unexpected results. To solve these issues, it is best to start fresh from factory defaults and use the manual as a step by step programming guide, rather than a random approach to programming. See *Reset Meter to Factory Defaults* on page 42 for details on resetting the meter to factory defaults. In addition, for best results, we recommend using the free MeterView XL software for all programming needs.

Symptom	Check/Action
No display at all	<ol style="list-style-type: none"> 1. Check that the 4-20 mA current loop is providing at least 3.5 mA to the meter. 2. Check that the voltage drop of all devices connected to the 4-20 mA current loop does not exceed the max rating of the loop power supply.
Not able to change setup or programming, LOCK is displayed	Meter is password-protected, enter correct five-digit password to unlock.
Meter display flashes: <ol style="list-style-type: none"> 1. 99999 2. --9999 	Check that the number of digits required for the scaled value does not exceed the maximum digits for the display line. If it does, try adjusting the decimal point location for less precision or changing the PV display to the bottom display.
Display is unstable	Check: <ol style="list-style-type: none"> 1. Input signal stability and value. 2. Display scaling vs. input signal. 3. Filter and bypass values (increase).
Display response is too slow	Check filter and bypass values
Display reading is not accurate	Check: <ol style="list-style-type: none"> 1. Input signal conditioner selected: Linear, square root, etc. 2. Scaling or calibration
Display does not respond to input changes, reading a fixed number	Check display assignment. It might be displaying max, min, or set point.
Display shows: <ol style="list-style-type: none"> 1. MAX and a number 2. MIN and a number 	Press Menu to exit max/min display readings.
Relay operation is reversed	Check fail-safe settings in <i>Output</i> menu
Relays do not respond to signal	Check: <ol style="list-style-type: none"> 1. Relay action in <i>Output</i> menu 2. Set and reset points 3. Check manual control menu
If the display locks up or the meter does not respond at all	Cycle the power to reboot the microprocessor.
Other symptoms not described above	Call Technical Support for assistance.

Contact BinMaster

Technical Support

Call: 402.434.9102

Email: support@binmaster.com

Sales Support

Call: 402.434.9102

Email: info@binmaster.com

Place Orders

Email: info@binmaster.com

For the latest version of this manual please visit

www.binmaster.com

BINMASTER

Division of Garner Industries LLC
7201 North 98th Street, Lincoln, NE 68507 USA
Tel (800) 278-4241 • Fax: (402) 434-9133
www.binmaster.com

BINMASTER

925-0364 REV B
LIM6602BM_B
SFT124 Ver 2.000 & up
05/24