

# **BINMASTER**

*Taking Control . . . To A Higher Level*

## **PRO I Series CAPACITANCE PROBE**



**OPERATING INSTRUCTIONS**  
**PLEASE READ CAREFULLY**

# **BINMASTER**

Division of Garner Industries  
7201 No. 98th Street P. O. Box 29709  
Lincoln, NE 68507 Lincoln, NE 68529  
(402) 434-9102 Fax (402)434-9133  
[www.binmaster.com](http://www.binmaster.com)

# TABLE OF CONTENTS

GENERAL SPECIFICATIONS.....	3
1.0 INTRODUCTION.....	4
2.0 APPLICATIONS .....	4
3.0 INSTALLATION .....	4
3.1 Location and Mounting.....	4
3.2 Input Power and Field Wiring.....	5
3.3 Grounding .....	5
4.0 FAIL-SAFE SELECTION.....	6
4.1 Description .....	6
4.2 Fail-Safe High .....	6
4.3 Fail-Safe Low .....	6
5.0 CALIBRATION .....	7
5.1 Calibration Verification .....	7
5.2 Calibration Procedure .....	7
5.3 Sensitivity Selection .....	7
6.0 TIME DELAY.....	8
7.0 WARRANTY AND CUSTOMER SERVICE .....	8
FIGURE 1.1 .....	9
FIGURE 1.2.....	10
FIGURE 1.3.....	11
FIGURE 1.4.....	12
FIGURE 2.1.....	13



**PRO I**  
**GENERAL SPECIFICATIONS**

<b>Supply:</b>	120/240 VAC 50/60 Hz
<b>Supply Tolerance:</b>	-15% +10%
<b>Load:</b>	5VA
<b>Ambient Temperature: (Electronics)</b>	-40° F to +185° F (-40° C to +85° C)
<b>Sensitivity:</b>	1 picofarad
<b>Enclosure:</b>	Type 4X, 5, 12
<b>Relay Output:</b>	DPDT contacts; 10 Amps 250 VAC
<b>Fail-Safe:</b>	Switch selectable "High" or "Low" level modes
<b>Calibration:</b>	Set when probe is uncovered: COARSE adjust; single turn potentiometer FINE adjust; single turn potentiometer
<b>Status Indicator:</b>	Internal LED indicates material in contact with probe.  External LED includes the time delay setting: Flashing -- Probe uncovered ON Solid -- Probe covered OFF -- Power failure
<b>Time Delay:</b>	Adjustable up to 10 seconds
<b>Probe Shield:</b> on the probe	Automatically compensates for material buildup
<b>Conduit Entry:</b>	3/4" NPT

## 1.0 INTRODUCTION

The Bin-Master PRO I is a point level control used to detect the presence or absence of solids or liquids. The PRO I operates on the capacitance principle and incorporates a "Quick Set" feature to simplify calibration. The PRO I includes switch selectable Fail-Safe output contacts and "Probe Shield" technology for ignoring material build-up. An external LED provides visual monitoring of probe covered, uncovered, and power failure conditions.

Upon installation the PRO I is set up with the probe uncovered. The "Quick Set" feature allows simple setup and calibration of the unit to achieve low, medium, or high sensitivity settings. The PRO I has an adjustable time delay for monitoring covered or uncovered conditions.

## 2.0 APPLICATIONS

For applications in pressurized vessels up to 1500 PSI, the PRO I should be mounted with the 3/4" stainless steel coupling.

Application temperatures for the various probes are:

1. Application temperatures for the various probes are:

1. Delrin Sleeved Stainless Steel: ... .250 Deg. F
2. Teflon Sleeved Stainless Steel: ....500 Deg. F
3. Flush Mount (Polyethylene): .....180 Deg. F
4. Flush Mount (Teflon): ..... 450 Deg. F
5. Bare Stainless Steel: .....250 Deg. F
6. Flexible Extension: .....250 Deg. F

The Delrin and Teflon sleeved stainless steel probe should be used when mounting the PRO I in a highly corrosive atmosphere. Bare metal stainless steel probes are suitable for granular or liquid material that is not electrically conductive. For electrically conductive material, a coated (insulated) probe must be used.

## 3.0 INSTALLATION

### 3.1 Location and Mounting

The probe should be located out of the direct flow of material. The PRO I is designed to mount utilizing either a standard 1 1/4" NPT coupling or optional 3/4" NPT coupling. When the PRO I is used with the flush mount probe, the flush mount probe mounts directly to the vessel wall using a 7" diameter bolt circle. Refer to Figures 1.1 through 1.4 for illustrations on installation, mounting options, and different probe combinations.

### 3.2 Input Power and Field Wiring

The PRO I can be powered from either a 120 VAC or 240 VAC supply (see diagram below). Field wiring should conform to all national and local electrical codes and any other agency or authority having jurisdiction over the installation.

120 VAC SUPPLY

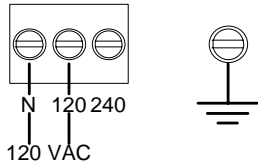

240 VAC SUPPLY

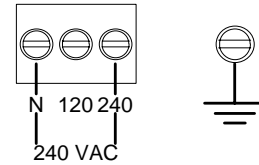

### 3.3 Grounding

An equipment grounding connection (earth ground) **must** be supplied to the unit for safety and to insure proper operation of the unit. This unit uses earth ground as a reference for calibration and detecting a covered or uncovered condition. Therefore, the vessel in which the PRO I is mounted must be made of metal, or a suitable metal ground plate must be installed where the PRO I is mounted.

## 4.0 FAIL-SAFE SELECTION

### 4.1 Description

The PRO I relay contacts are DPDT. They are rated to switch up to 10 Amps at 250 VAC. These contacts are dry contacts. Power applied to the C terminals is switched between the NC and NO terminals. A connection is made between 1C and 1NC, and between 2C and 2NC when the relay is de-energized. When the relay is energized these connections are broken and there is then a connection between 1C and 1NO, and between 2C and 2NO.

A Fail-Safe condition means that the relay contact positions are set up so that in the event of a power failure, the relay will be de-energized and the contacts will indicate a condition that is deemed safe for the application. (Refer to FIGURE 2.1 for the location of the Fail-Safe selection switch.)

### 4.2 Fail-Safe High

Fail-Safe High means that the relay will be energized when the probe is uncovered and will de-energize when the probe is covered. In this mode, a power failure will cause the relay contacts to indicate that the probe is covered whether it is or not.



### 4.3 Fail-Safe Low

Fail-Safe Low means that the relay will be de-energized when the probe is uncovered and will energize when the probe is covered. In this mode, a power failure will cause the relay contacts to indicate that the probe is uncovered whether it is or not.

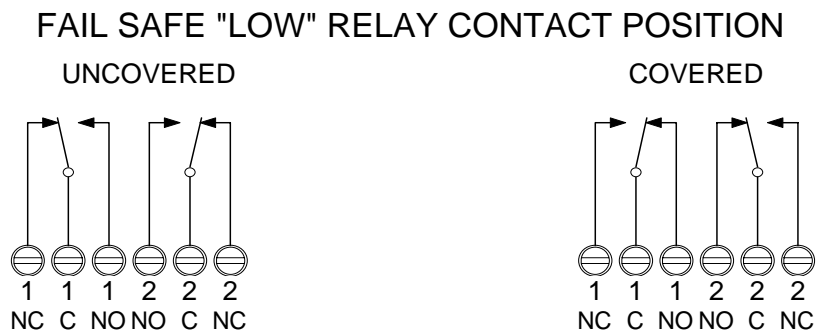

## 5.0 CALIBRATION

The PRO I Quick Set calibration feature uses two single turn potentiometers making calibration very simple. One potentiometer labeled COARSE is used to compensate for the capacitance of the empty vessel. The other potentiometer labeled FINE is used to set in the desired sensitivity. Refer to FIGURE 2.1 for the location of these potentiometers on the printed circuit board. A tool for adjusting the COARSE and FINE potentiometers is provided inside the top cover of the PRO I. The cover has a convenient clip for storing the tool so it will always be available.

**NOTE: Accurate calibration requires that the appropriate probe be attached to the PRO I and the unit installed in the vessel. The probe must be UNCOVERED and material well below it.**

### 5.1 Calibration Verification

Following calibration adjustment, the sensitivity setting that you have selected should be checked by verifying that the PRO I senses a covered probe condition with your material.

### 5.2 Calibration Procedure

1. Turn both the COARSE and FINE potentiometers fully counter clockwise (CCW). The internal COVERED indicator light should be OFF.
2. Turn the COARSE potentiometer slowly clockwise (CW) to the point where the COVERED indicator light just turns ON and stays on.
3. Turn the FINE potentiometer slowly clockwise (CW) until the COVERED indicator light just turns OFF. ( If the COARSE potentiometer has been carefully adjusted, this should occur when the FINE potentiometer is between the 8 and 10 O'clock position.) Now continue to turn the FINE potentiometer clockwise (CW) to the desired sensitivity setting.

HIGH sensitivity:	1/16 to 1/8 turn ( 1 to 3 picofarad )
MEDIUM sensitivity:	1/8 to 1/4 turn ( 3 to 6 picofarad )
LOW sensitivity:	1/4 to 1/2 turn ( 6 to 12 picofarad )

**NOTE:** It may be convenient to think of the FINE potentiometer as a clock face where the distance between consecutive hour numbers represent a change in sensitivity of approximately 2 picofarad. Thus turning the FINE potentiometer clockwise one hour position past the point at which the COVERED indicator just turns OFF would provide a sensitivity of approximately 2 picofarad. Two hour positions past that point would provide approximately 4 picofarad sensitivity, etc.

### 5.3 Sensitivity Selection

Sensitivity Setting ( typical )	Dielectric Constant of Material
HIGH sensitivity:	4 or less
MEDIUM sensitivity:	4 to 10
LOW sensitivity:	10 or higher

## 6.0 TIME DELAY

The PRO I has an adjustable time delay of up to 10 seconds. This is a time delay for the output to change states from an uncovered to a covered condition and from a covered to an uncovered condition. This time delay affects the relay contacts only. The internal LED (DS1) will immediately respond to a change in covered or uncovered condition regardless of the time delay setting.

Minimum time delay is when the DELAY potentiometer is set fully counter-clockwise. (Refer to FIGURE 2.1 for the location of the DELAY potentiometer.) Maximum time delay is with the DELAY potentiometer set fully clockwise.

A tool for adjusting the TIME DELAY potentiometer is provided inside the top cover of the PRO I. The cover has a convenient clip for storing the tool so it will always be available.

## 7.0 WARRANTY AND CUSTOMER SERVICE

### 7.1 LIMITED WARRANTY

The manufacturer warrants this equipment for two (2) years according to the following terms:

- 1.) This warranty extends to the original purchaser only and commences on the date of original purchase. The original purchaser must mail to the manufacturer the "Warranty Registration" card to confirm the equipment purchase. Failure to do so may void the warranty.
- 2.) The manufacturer will repair or replace any part of this equipment found to be defective, provided such part is delivered prepaid, to the factory. Manufacturer's obligation is limited to the cost of material and labor to repair or replace and does not include transportation expenses.
- 3.) This warranty shall not apply to any product which has, in our judgment, been tampered with, altered, subject to misuse, neglect or accident. In addition, the warranty does not extend to repairs made necessary by normal wear.
- 4.) This warranty is in lieu of all other warranties, expressed or implied.

### 7.2 CUSTOMER SERVICE

Bin Master offers a toll-free Customer Service phone number **1-800-278-4241**. You may call the Customer Service Department for technical and application assistance Monday through Friday from 8:00AM to 5:00 PM Central Time. International customers call us at **(402) 434-9102** or reach us via **fax** at **(402) 434-9133**.

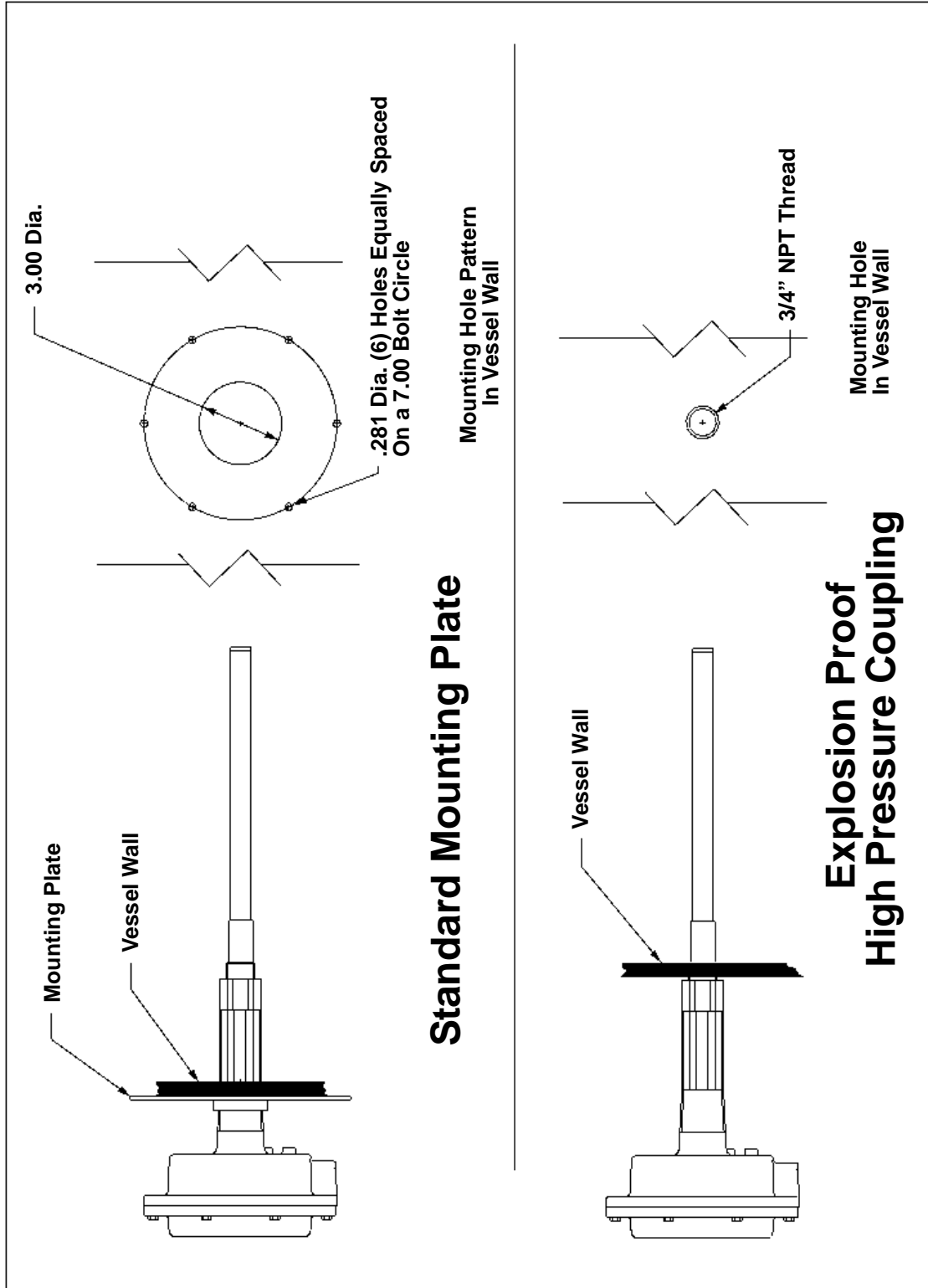
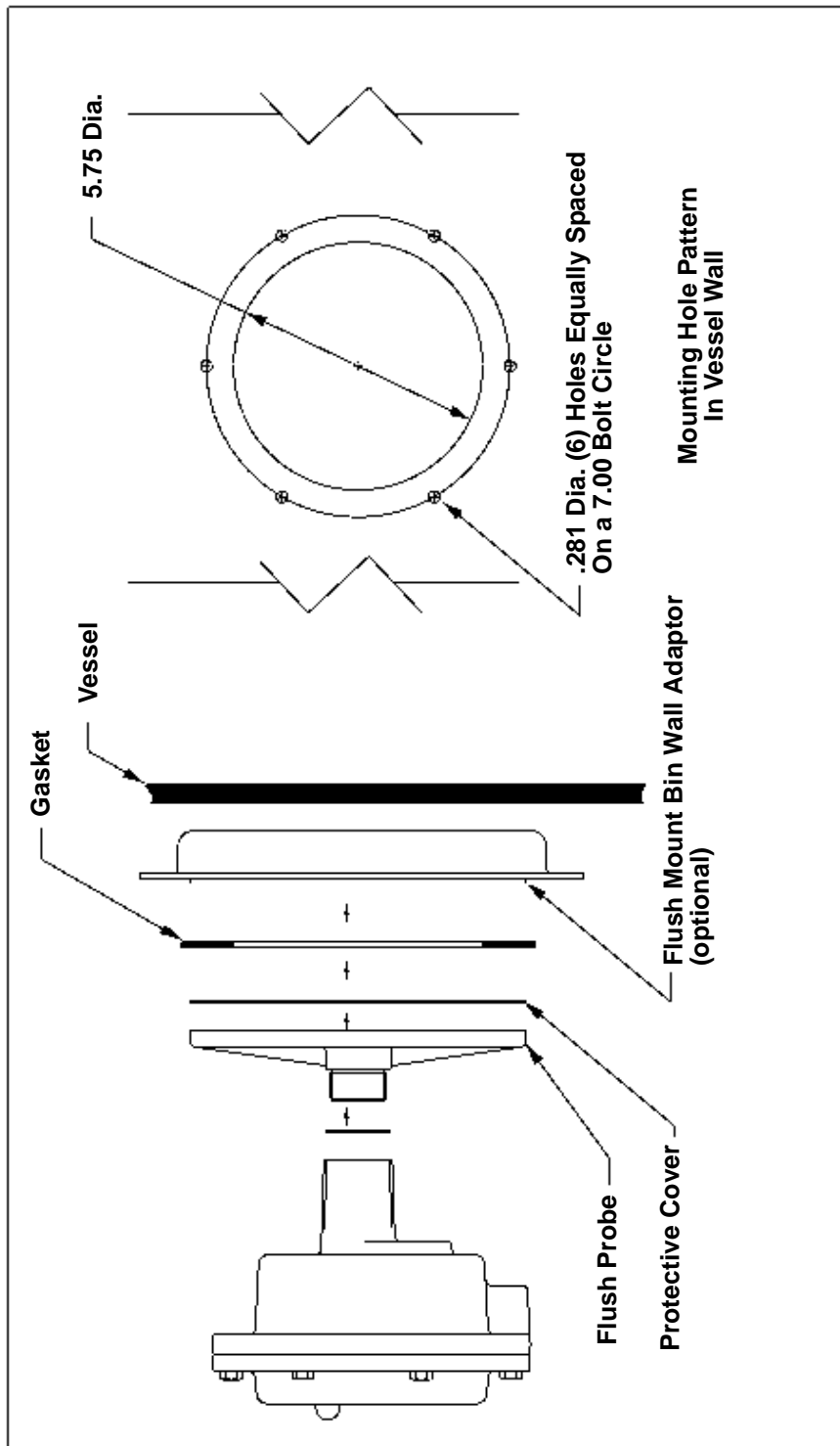
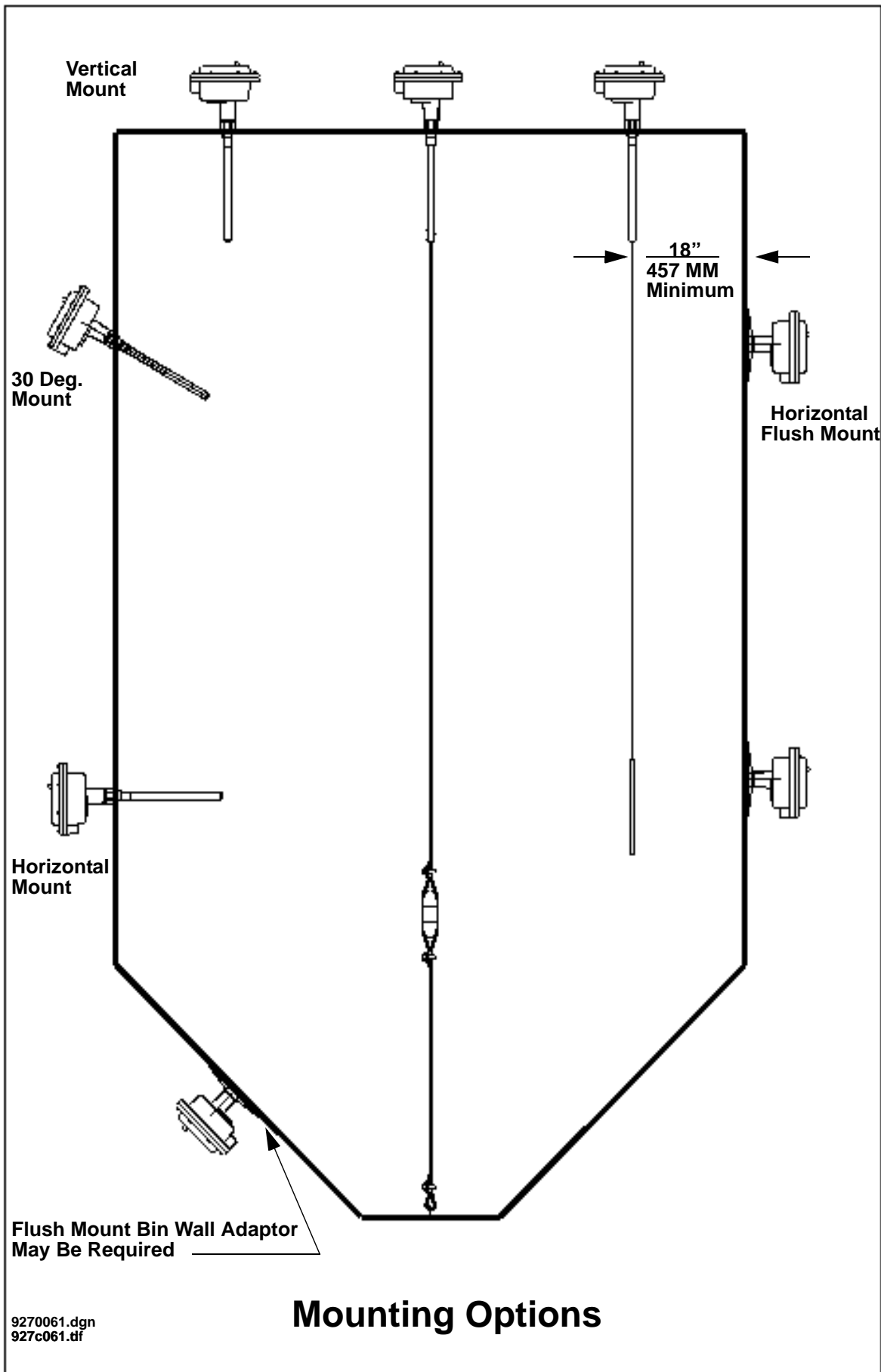

Figure 1.1



## Flush Mount Probe

Figure 1.2



9270061.dgn  
927c061.tif

Figure 1.3  
11

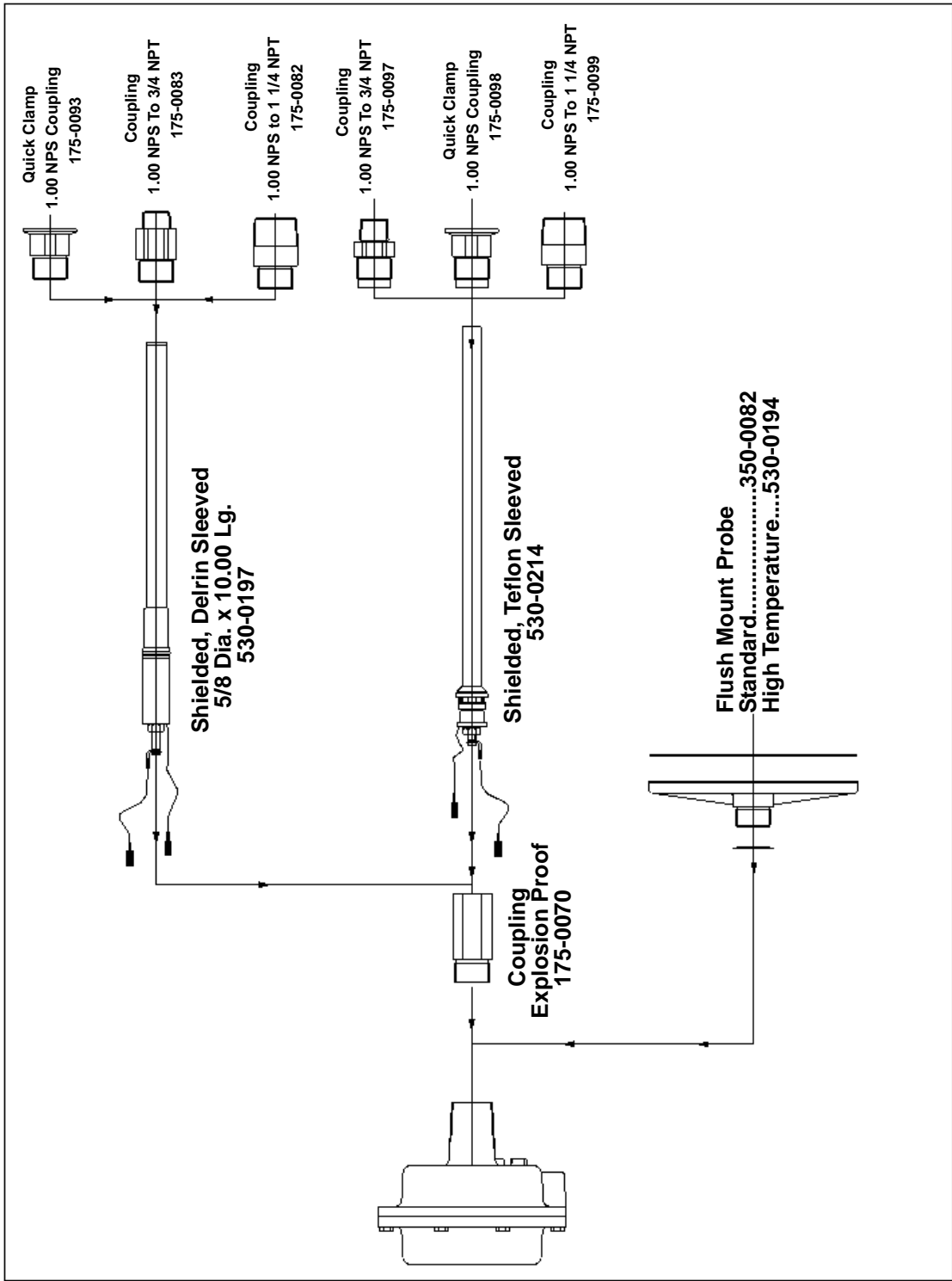

# PRO X Probe Combinations

Figure 1.4

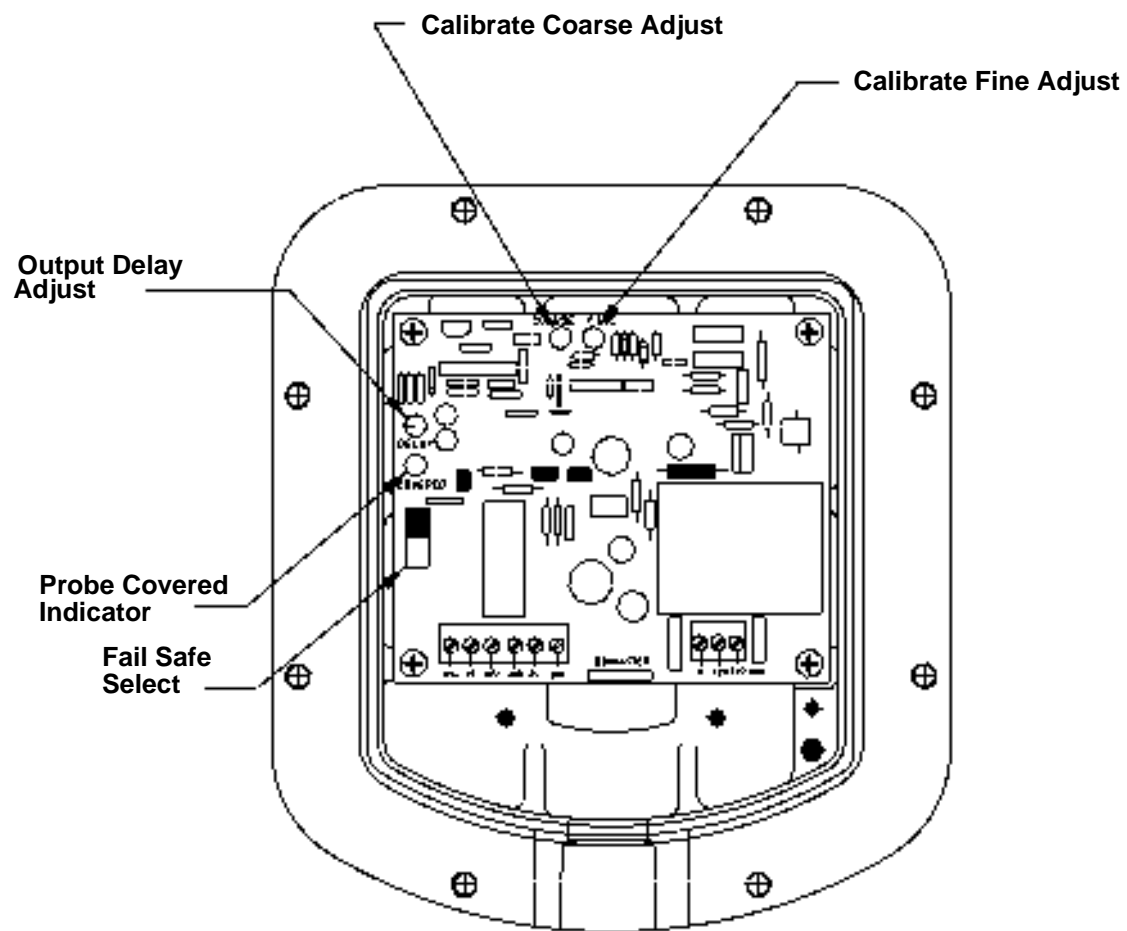

# PRO I Capacitance Probe

## Parts list

Reference Figure 1.5

Item	Part No.	Description
1	220-0201	Cast Aluminum Cover
2	280-0022	Gasket "O-ring" Cover
3	530-0072	PC Board Assembly
4	220-0202	Cast Aluminum Enclosure
5	175-????	Fitting (Consult Factory)
6	530-????	Probe (Consult Factory)
7	335-0071	Lens Cover

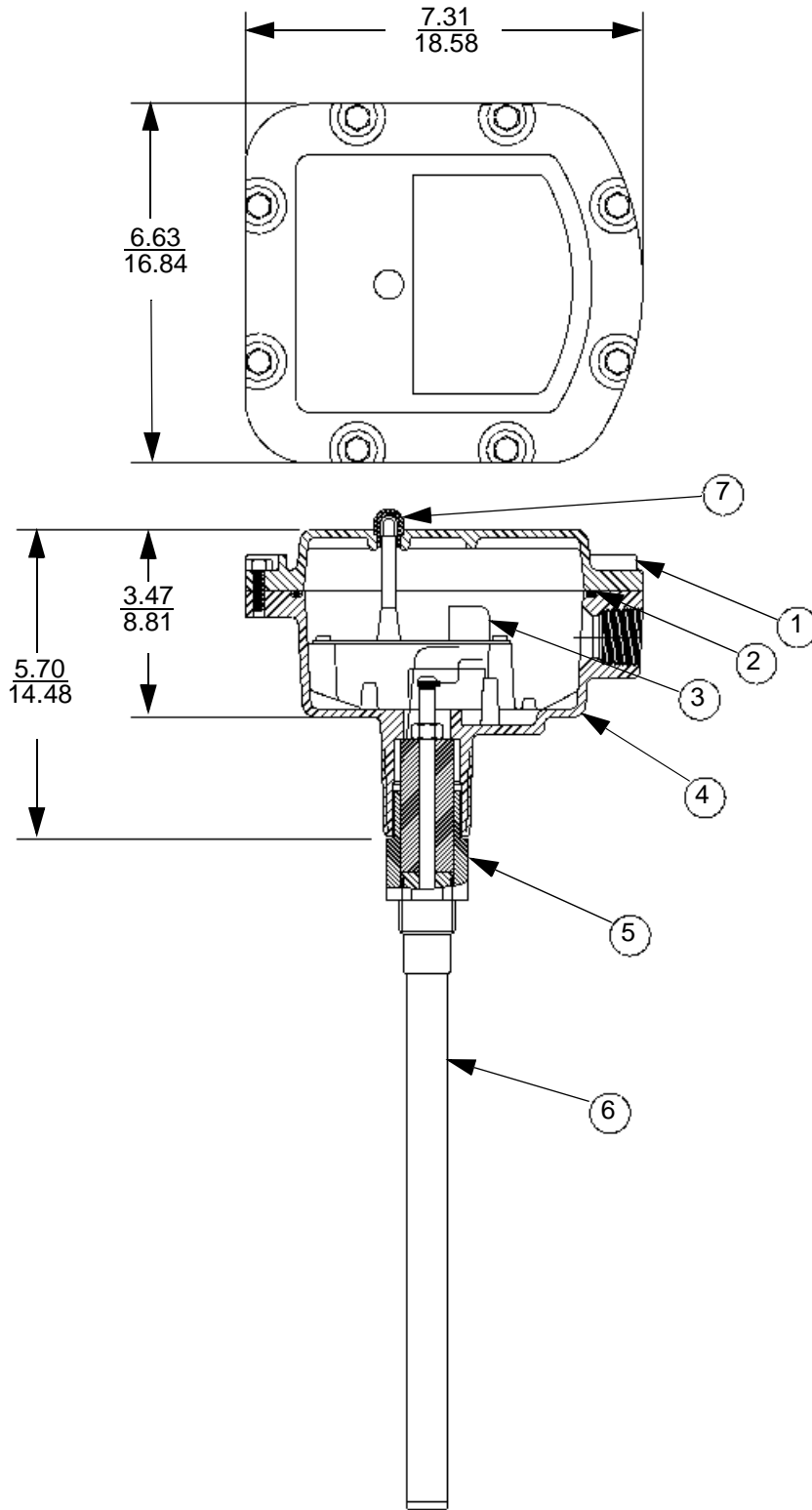

IN/CM

Figure 1.5

# Mounting Instructions

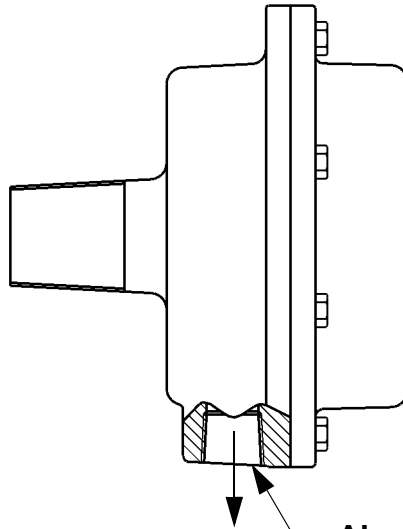

Always Mount Unit with Conduit Opening Down

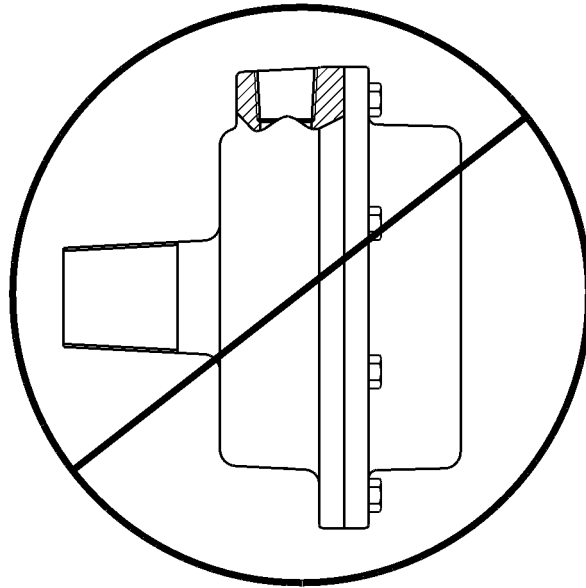

## CONDUIT SEAL

When installing this level indicator in environments where it is possible for moisture or moist air to enter the enclosure thru the electrical conduit, the conduit opening should be sealed with a duct seal compound or putty appropriate for the purpose.

# **BINMASTER**

Division of Garner Industries  
7201 No. 98th Street P. O. Box 29709  
Lincoln, NE 68507 Lincoln, NE 68529  
(402) 434-9102 Fax (402) 434-9133  
[www.binmaster.com](http://www.binmaster.com)