

BINMASTER

Taking Control . . . To A Higher Level

FLOW DETECT 1000 DOPPLER FLOW DETECTION



**INSTALLATION AND OPERATING INSTRUCTIONS
READ THOROUGHLY BEFORE INSTALLING EQUIPMENT**

BINMASTER

Division of Garner Industries
7201 No. 98th Street P. O. Box 29709
Lincoln, NE 68507 Lincoln, NE 68529
(402) 434-9102 Fax (402)434-9133
www.binmaster.com

TABLE OF CONTENTS

Description	3
Principle of Operation	3
Detection Through Walls	3
Sensing Beam Shape	3
Installation Considerations	4
Application and Mounting	4
Wiring Power and Relay Circuits	5
Wiring Between FDC1000 – FDS1000	6
Calibration Procedure	6
Sensitivity Adjustment Procedure	7
FDS1000 Sensor Indicator Lights	7
FDC1000 Control Unit Indicator Lights	7
Loop Fault Indicator	8
Troubleshooting	8
Maintenance	8
Flow Detect 1000 Specifications	9

INSTALLATION & OPERATION

FLOW DETECT 1000

MODEL FDS1000

DESCRIPTION

The Flow Detect 1000 is an industrial instrument that senses flow or no-flow conditions of solids and powders in pneumatic pipelines, gravity chutes and feeders. It uses Microwave Doppler technology to provide highly sensitive motion detection. The sensor probe is completely non-intrusive, avoiding contact with the flow stream and associated wear problems. It is designed for high reliability and has no moving parts to wear out.

The Flow Detect 1000 is a two-part system consisting of the Model FDS1000 low power microwave sensor and the model FDC1000 associated control unit. The FDS1000 sensor can be located up to 2500 feet away from the control unit. For convenience of setup and operation, all calibration and operating adjustments are located in the FDC1000 control unit that has a NEMA 4X enclosure with hinged cover for easy access.

PRINCIPLE OF OPERATION

The FDS1000 sensor unit emits a low power microwave signal toward the material being monitored. Part of this signal is reflected off the material back to the antenna of the FDS1000. This reflected signal combines with the emitted signal to produce a beat frequency, which is the difference in frequency between the two signals. If the material being monitored is not moving, the reflected signal will be the same frequency as the emitted signal and there will be no beat frequency produced. However, if the material is moving, the reflected signal will be shifted in frequency and a difference or beat frequency will be produced. This shift in frequency is called the Doppler effect. The presence or absence of this beat frequency is sensed by the FDS1000 to detect a flow or no flow condition.

Most of us have experienced the Doppler effect when listening to a train horn as the train approaches and passes. As the train approaches, its horn has a higher pitch because the velocity of the train toward us causes the sound waves to reach us at a faster rate. As soon as the train passes us, its velocity away from us causes the sound waves to reach us at a slower rate and the pitch of its horn shifts down in frequency.

DETECTION THROUGH WALLS

Microwaves are extremely high frequency radio waves and as such pass through nonmetallic materials with negligible attenuation. The FDS1000, therefore, can "see through" a plastic pipe, or glass process seal, or the wall of a wooden shoot to detect the motion of material inside. This also means that the FDS1000 can look all the way through a plastic pipe or wooden shoot and see a person walking on the other side. Therefore, in some installations where this situation may occur, a metallic material will need to be placed on the opposite side of the pipe or shoot to prevent the FDS1000 from seeing objects on the other side. In some cases, adjusting the sensitivity of the FDS1000 to a lower setting can simply eliminate the sensing of moving objects on the other side of a nonmetallic pipe or shoot.

THE SENSING BEAM SHAPE

The microwave signal emitted from the FDS1000 Sensor is a focused beam produced by a horn antenna inside the enclosure neck. You can imagine this beam by thinking of the enclosure as a flashlight with a beam of light shining outward from the neck. This narrow beam must be directed at the moving material to be monitored.

INSTALLATION CONSIDERATIONS

The FDS1000 Sensor is approved as intrinsically safe for Class II Groups E, F, & G when used with the FDC1000 Control unit. The FDC1000 Control unit serves as the Intrinsic Safe Barrier between the high-energy circuits of the 120VAC input and relay contact circuits, and the safe low energy connection to the remote FDS1000 sensor. A five-wire cable from the FDC1000 control unit provides low energy intrinsically safe power and communication to the remote sensor. The FDC1000 control unit must be located in a non-hazardous area, while the FDS1000 sensor can be located in a hazardous environment of the appropriate classification.

APPLICATIONS AND MOUNTING OF FDS1000 SENSOR

The FDS1000 flow sensor unit is mounted at the process site where the movement of material is to be monitored. Often this will be on the side of a chute or flow pipe where access by personnel is difficult or limited. For this reason, there are no user adjustments located in the FDS1000 sensor unit. When selecting a location, attention should be given to the temperature limits of the device to make sure they are not exceeded. The unit should also be mounted where it will not experience vibration as this may be detected as motion and give a false indication of flow.

The sensor best detects movement of material directly toward or away from the unit. However, mounting the unit perpendicular to flow usually works because there is adequate fluctuation of material as it flows past to allow detection. In some cases where the material is very light and difficult to detect, it may be necessary to mount the unit at some angle off perpendicular to the flow. An angle of 20 to 30 degrees from perpendicular is usually sufficient, see Figure 1.

For mounting, the FDS1000 unit has a threaded neck with a 1-1/4 NPST. There are mounting adapters available for various situations as illustrated in Figure 2.

For installations where the sensor needs to monitor flow through a metal pipe or chute, an opening will have to be made in the metal wall. If necessary, a suitable seal made of nonmetallic material should be provided for this opening. For some installations, the seal provided on the FDS1000 sensor would be adequate. Care must be taken so as not to exceed the pressure or temperature rating of the seal or electronics of the FDS1000.

To Summarize, the FDS1000 sensor should be installed such that:

- Its temperature ratings are not exceeded
- The pressure rating of its process seal is not exceeded
- It does not experience appreciable vibration
- An opening is provided in metallic shoots or pipes
- If necessary, mounted off perpendicular to material flow

WIRING OF POWER AND RELAY CIRCUITS

The NEMA 4X enclosure is not supplied with a conduit opening to accommodate the power and relay wiring. The placement and size of this opening depends upon specific installation needs and is left to the discretion of the installing electrician. To maintain the Intrinsic Safe rating, the power and relay contact wiring must not use the same entry as the cable to the FDS1000 sensor unit.

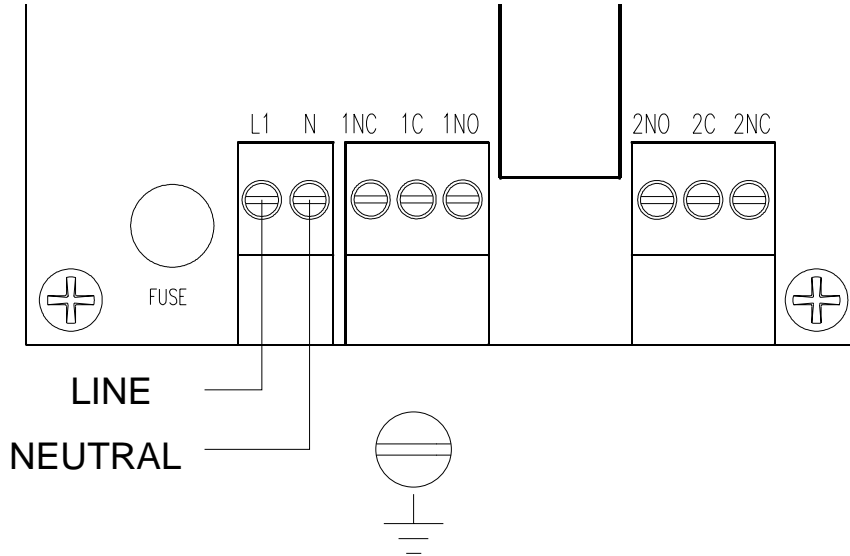

The FDC1000 control unit is powered from 120VAC 50/60Hz at 5VA. Wiring to the unit must comply with the National Electrical Code and local codes. A DPDT relay provides dry contacts for operation of auxiliary alarms or controls at the users discretion. These contacts are rated for 5A at 240VAC or 30VDC.

NOTE: The normally open, NO, and normally closed, NC, relay contact nomenclature shown on the PC board of the FDC1000 is for the relay in its non-energized, ALARM, condition.

RELAY CONTACT POSITION WITH ALARM SWITCH SET TO NO FLOW

MATERIAL FLOWING

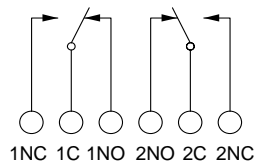

MATERIAL NOT FLOWING

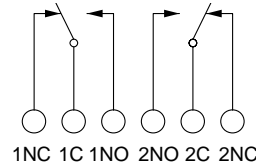

RELAY CONTACT POSITION WITH ALARM SWITCH SET TO FLOW

MATERIAL FLOWING

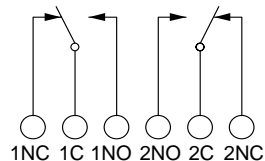

MATERIAL NOT FLOWING

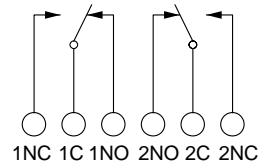

WIRING BETWEEN FDC1000 AND FDS1000

The FDC1000 control unit serves as an Intrinsically Safe barrier providing low energy output circuits to the FDS1000 sensor. A five-conductor cable is required for interconnection. Simply connect each wire of the cable to corresponding terminals in the sensor and control units as shown in Figure 3. Wire size of at least 18AWG is suitable for distances up to 1500 feet, and 16AWG for distances up to 2500 feet. Use a cable with an O.D. between .200 and .470 in. and a temperature rating appropriate for your application. Suggested cable types are listed below.

18AWG	Belden	8465	60 degree C
	WEICO	4005/1880	degree C
16AWG	Belden	9620	80 degree C

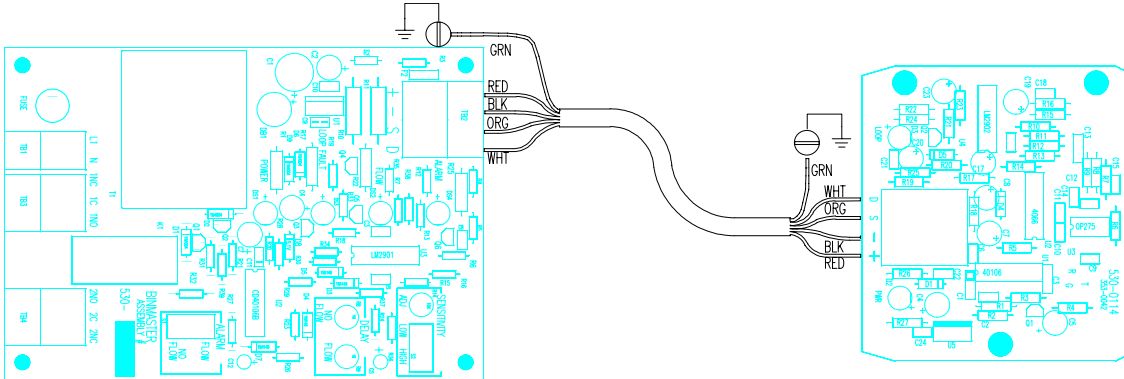

CALIBRATION PROCEDURE

For user convenience, all adjustments and indicating lights are located in the FDC1000 control unit. A suitable tool for making the adjustments is held in a retaining clip inside the hinged enclosure cover of the FDC1000. A description of each setting or adjustment follows.

ALARM

FLOW
NO FLOW

Select the condition you desire to be the alarm condition. The output relay will be de-energized for the condition you select.

NOTE: The adjustable devices on the FDC1000 circuit board are delicate electronic components, do not apply excessive force when making adjustments.

DELAY

FLOW
NO FLOW

Delays relay operation for the stated condition.
Set for desired delay when sensing FLOW.
Set for desired delay when sensing NO FLOW.

SENSITIVITY

LOW / HIGH SWITCH
ADJ, ADJUSTMENT

Normally set to the LOW position.
Adjust as described in the paragraph below.

Sensitivity Adjustment Procedure:

1. Start with the ADJ control turned full counter clock wise to the 7 O'clock position.
2. With no material flowing, FLOW light off, turn the ADJ control clockwise to the point where the FLOW light just turns on and note this position. This will normally be the 3 O'clock position.
3. Start material flowing. With material flowing, slowly turn the ADJ control counter clockwise until the FLOW light just turns off* and note this position.

* In some cases with easily detected material, the FLOW light will not turn off, if this is the case proceed to step 4.

* In some cases with hard to detect material, the FLOW light will turn off very close to the no material flowing 3 O'clock position. If this is the case, set the sensitivity switch to the HIGH position and repeat steps 1 through 3.

4. Set the ADJ control half way between the points noted in steps 2 and 3.
If in step 3 the FLOW light never turned off, set the ADJ control to the 11 O'clock position.

FDS1000 SENSOR INDICATOR LIGHTS

The FDS1000 has two internal LED indicator lights that function only as troubleshooting aids. During normal operation, both of the lights will be lit. The GREEN LED indicates that power is being properly supplied from the FDC1000 control unit. The RED LED indicates that current is flowing in the communications loop to the control unit. This RED LED will increase in brightness when motion is being detected.

FDC1000 CONTROL UNIT INDICATOR LIGHTS

The FDC1000 control unit contains all of the operator adjustments and indicating lights and should in a location easily accessed by personnel. The following table describes the condition indicated by each light.

INDICATOR LIGHTS

POWER (GREEN)	INDICATES THAT POWER IS APPLIED TO THE FDC1000 CONTROL UNIT
LOOP FAULT (RED)	INDICATES AN OPEN OR SHORT IN THE WIRING TO THE FDS1000 SENSOR UNIT
FLOW (YELLOW)	INDICATES WHEN FLOW (MOTION) IS SENSED
ALARM (RED)	INDICATES WHEN THE SELECTED ALARM CONDITION EXISTS, OUTPUT RELAY DE-ENERGIZED

LOOP FAULT INDICATOR

The FDC1000 control unit continuously monitors the communications loop wiring to the FDS1000 sensor. In case of an open or shorted circuit, the LOOP FAULT red LED will light and the FDC1000 output relay will de-energize to an ALARM condition.

TROUBLESHOOTING

The indicator lights of both the FDS1000 sensor and the FDC1000 control unit are important aids for diagnosing trouble. Review the paragraphs on the LED Indicator Lights if you are not familiar with their functions.

Most trouble encountered with new installations is due to (1) a wiring error (2) improper alignment of the sensor beam toward the material (3) incorrectly set adjustments.

1. Verify that the wiring is correct and power is applied. In the FDC1000, the green power LED should be on and the red loop fault LED off. In the FDS1000, both the green and red LEDs should be on.
2. Verify proper alignment of the FDS1000 sensor beam toward the material. The red LED in the FDS1000 should increase in brightness when flow of material is sensed. Reposition the sensor if necessary.
3. Verify correct settings of adjustments. See calibration procedures.
 - a. When flow is sensed by the FDS1000, the yellow sense LED on the FDC1000 should turn on. If not, increase the sensitivity setting.
 - b. Verify the setting of alarm (relay operation) delay for FLOW and NO FLOW. For troubleshooting it is often convenient to use short delays.

MAINTENANCE

The FDS1000 sensor and FDC1000 control are to be serviced by the BinMaster Division of Garner Industries only. For service information call **1-800-278-4241**.

WARNING: The FDS1000 sensor is an intentional radiator of RF energy, certified under Part 15 of the FCC Rules. Changes or modifications to the FDS1000 not expressly approved by Garner Industries for compliance could void the user's authority to operate the equipment.

FLOW DETECT 1000 SPECIFICATIONS

FDS1000 SENSOR UNIT

Enclosure:	Aluminum, urethane powder coat, NEMA 4X
Operating Temperature:	-22° to +158° F (-30° to +70° C)
Process Temperature Max.:	250° F (121° C) if ambient air temperature around enclosure is below 150° F (65°C)
Power Requirement:	18VDC, provided by FDC1000 Control Console
Process Seal:	Neoprene (Teflon in optional stainless steel fitting)
Process Pressure:	80 psi (300 psi for optional stainless steel fitting)
Process Connection:	1-1/4" NPT (flush mount with half coupling)
Conduit Connection:	3/4" NPT
Interconnect Wiring:	5 Conductor cable to FDC1000 Control Console
Detection Range:	Up to 10 feet depending on type and size of target
Indicators:	Green LED – Power Red LED - Loop Current
Emission:	24.125 GHz, less than 1mW/cm ² (OSHA limit is 10mW/cm ²)
Approvals:	NRTL /C Intrinsically Safe, Class II Groups E, F, & G when connected to the FDC1000 Control Console FCC Part 15 Certification

FDC1000 CONTROL UNIT

Enclosure:	8"x6"x4" Fiberglass, NEMA 4X, 12, 13, flange mount
Operating Temperature:	-30° to +158° F (-35° to +70° C)
Power Requirements:	115VAC 50/60 Hz, 5VA (230 VAC available)
Interconnect Wiring:	5 Conductor cable to FDS1000 Sensor, Intrinsically Safe
Output:	Relay, DPDT dry contacts, 5A, 250 VAC or 30 VDC
Indicators:	Green LED – Power Red LED - Loop Fault Yellow LED - Sense Flow Red LED – Alarm
Sensitivity Setting:	High/Low selection switch
Sensitivity Adjustment:	Single turn calibration
Alarm Time Delay:	FLOW - single turn, 0.2 to 12 seconds NO FLOW - single turn, 0.2 to 12 seconds
Alarm Fail-Safe:	Switch selectable, FLOW or NO FLOW
Approvals:	NRTL /C Intrinsically Safe output Class II Groups E, F, & G to FDS1000 Sensor

Mounting Instructions

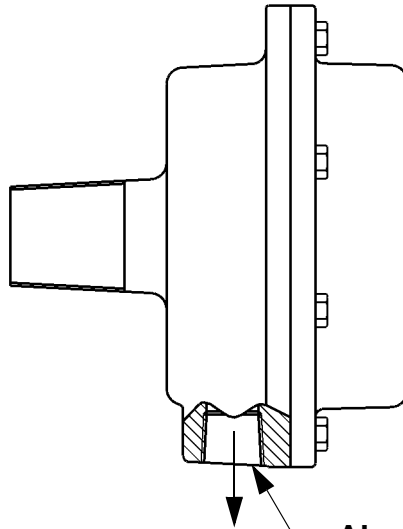

Always Mount Unit with Conduit Opening Down

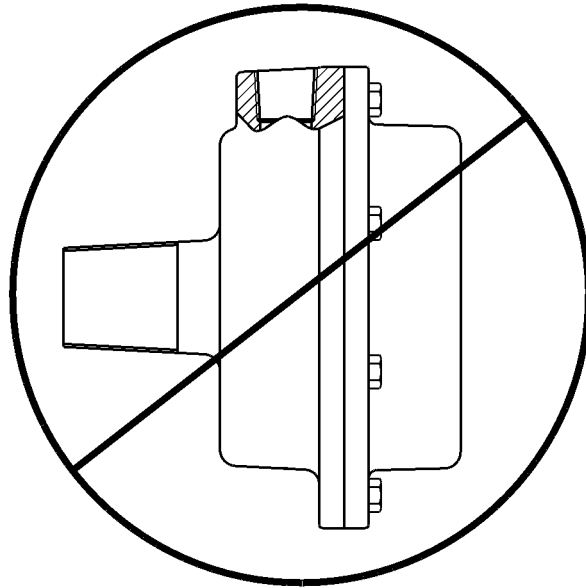

CONDUIT SEAL

When installing this level indicator in environments where it is possible for moisture or moist air to enter the enclosure thru the electrical conduit, the conduit opening should be sealed with a duct seal compound or putty appropriate for the purpose.

BINMASTER

Division of Garner Industries
7201 No. 98th Street P. O. Box 29709
Lincoln, NE 68507 Lincoln, NE 68529
(402) 434-9102 Fax (402) 434-9133
www.binmaster.com